

NPI DISTRIBUTION TRAINING (AMERICAS)

SGD43S-M3-Sx & STCC4

August 1, 2025 (1:00 pm CST)

THE PANELISTS



Jacek Pieczaba
FAE Manager



Maureen Rakotondraibe
Field Application Engineer



Diane Haynes
Senior Channel Manager

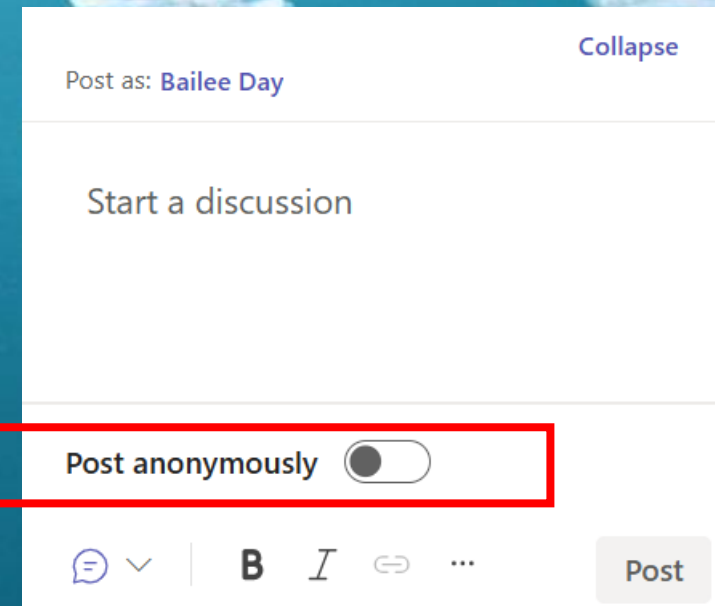
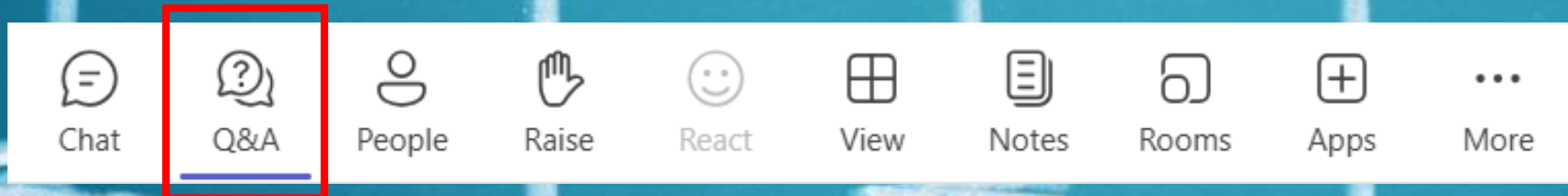

Q&A AT THE END

Introduction to Sensirion's Certificate Program

Every participant joining our NPI trainings will receive a **certificate of attendance**



There will be a **test** at the end of the training after the Q&A.

The best 3 scores at the final test will get a **personalized certificate of completion (with LinkedIn URL)** and evaluation kits of the sensors presented



We will have a virtual training every 2 NPIs and will inform you soon on the implications of the **certificate program**

STAY TUNED! 😊



SGD43S-M3-SX TRAINING SLIDES

Integrated refrigerant detection system.

Jacek Pieczaba, Field Application Engineer Manager
August 2025



An aerial view of a rooftop HVAC system. The system consists of numerous white, rectangular air conditioning units arranged in a grid pattern. Each unit has a circular fan on top and a mesh grille on the front. The units are mounted on a metal structure with railings. In the background, a building with windows is visible.

CHAPTER 1

Application

Introduction to A2L

The Need for Refrigerant Detection Systems (RDS)

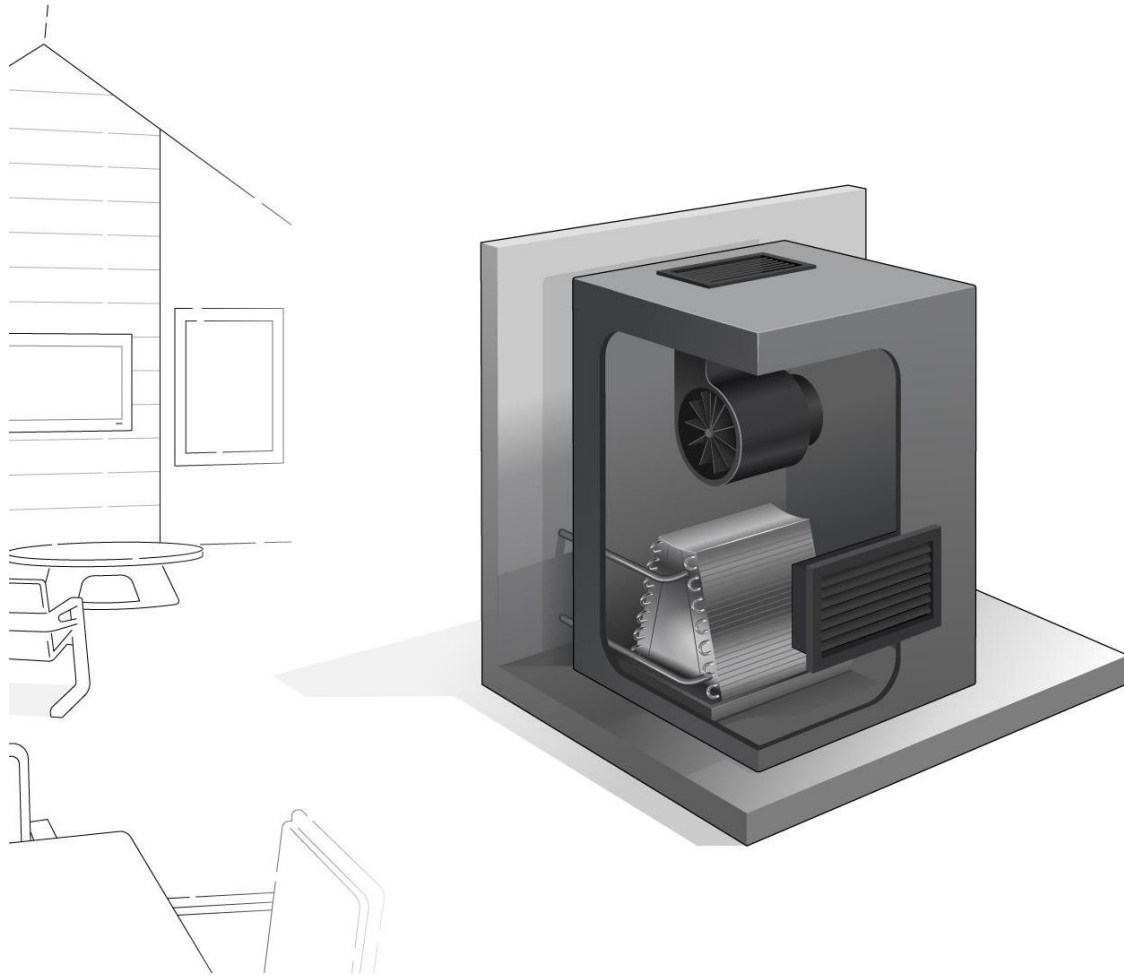

Why are A2L refrigerants used?

A2L refrigerants are being adopted worldwide because they have a lower Global Warming Potential (GWP) than traditional refrigerants.

Why are A2L refrigerant detection systems (RDS) required?

Due to the mild flammability of A2L refrigerants, safety standards like UL 60335-2-40 and UL 60335-2-89 in the US & CA mandate the use of refrigerant detection systems to prevent potential fire hazards in appliances with considerable amounts of refrigerant, unless a fan is run continuously.

What does an A2L refrigerant detection system do?

An A2L refrigerant detection system monitors the air for leaks of A2L refrigerants. If a leak is detected, it triggers alerts or safety measures to prevent dangerous situations.

More information available under [A2L leakage detection](#)

HVAC-R Appliances

Different refrigerants for different applications

HVAC

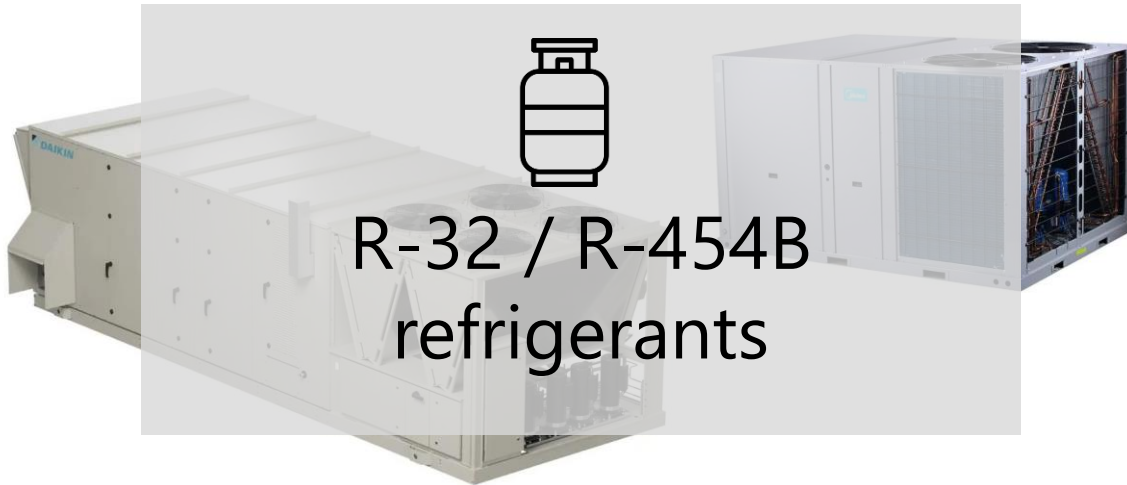

Refrigeration



Two architectures: 5V + mitigation board vs. integrated RDS

When does an integrated refrigerant detection system make sense?

Cased coil



RDS Option 1: A2L Sensor + control board



5V
RS-485

Mitigation
(+control) board

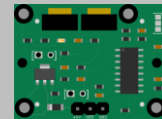

24V AC

contactors

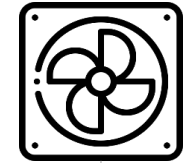
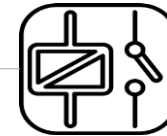

fan

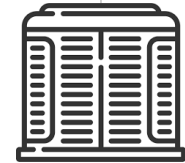

compressor

RDS Option 2: Integrated RDS



24V AC relay output

+ already certified as RDS
+ no mitigation board

contactors

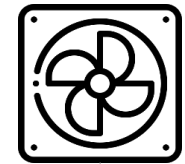
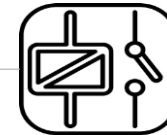

fan

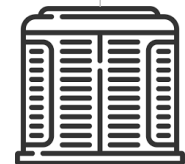

compressor

CHAPTER 2

Product Introduction



Thermal conductivity for A2L detection

Reliable sensing technology when safety is non-negotiable

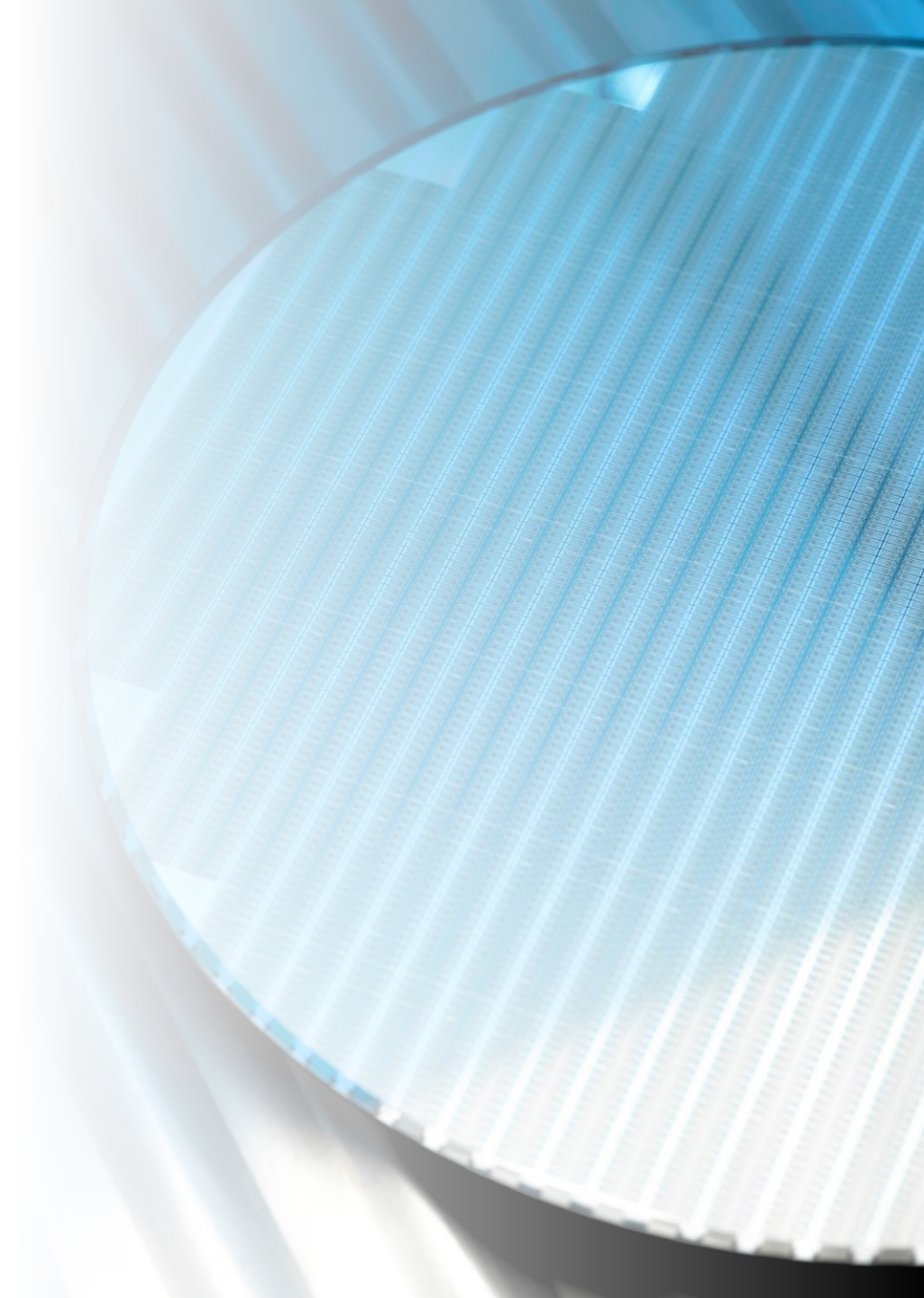
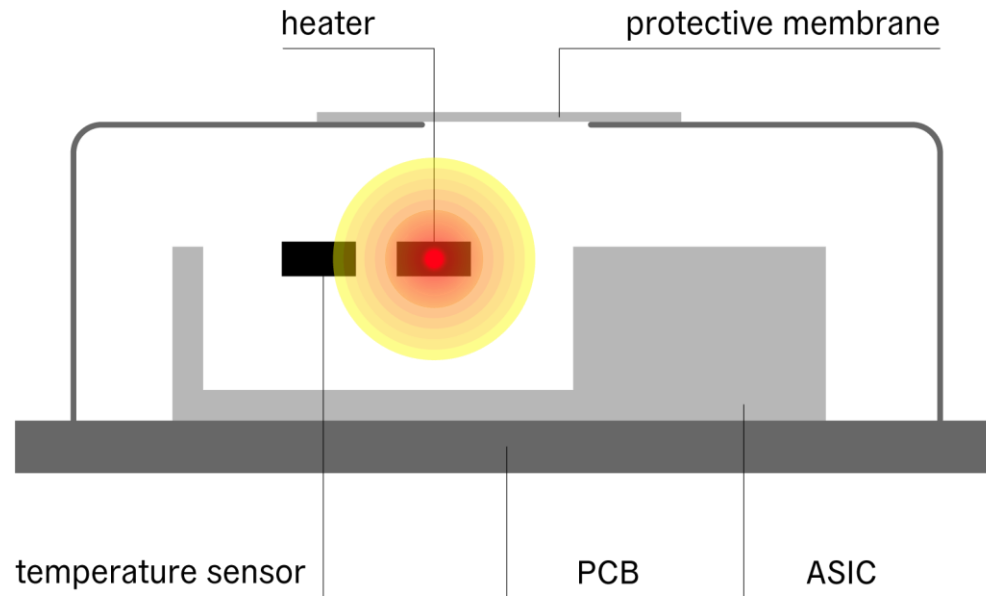

Based on Sensirion's STC component

A proven chip platform

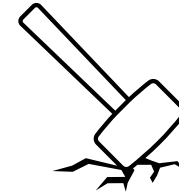

Proven Reliability

Made from robust, long-term stable materials



Simple measurement

Uses simple heaters and thermopiles.
No optical, chemical, or vibrating parts involved.



Thermal conductivity
sensing chip

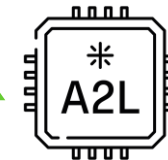

Scalable sensing platform

MEMS-based sensing platform for high scalability, in production since many years for automotive, industrial and medical applications

Refrigerant detection system

Sensor + mitigation board

- Combines A2L detection + mitigation board
- 24V AC and DC supply
- Relay output

- Design lifetime of 15 yrs
- Operational temperature of -40 to 85 °C
- Operational humidity range of 0 to 100 %RH

- RH/T compensated
- Anti-condensation measures



Features of the SGD43S-M3-Sx

Connecting safety, compliance and reliability for peace of mind



Multi-Calibration of the SGD43S-M3-Sx

Advantage for OEMs and Installers using uncharged coils

- **Challenge: Refrigerant Selection On-Site**

If installer decides the refrigerant after delivery of the uncharged coil, without multi-calibration, installer must stock different sensors for each refrigerant type.

- **Flexibility with multi-calibration A2L sensing**

OEMs/Installers don't need to worry about which refrigerant will be used in the field.

Available Variants:

SGD43S-M3-S5 HVAC

Dual calibration R-32 / R-454B

SGD43S-M3-S7 REF

Triple calibration R-454A / R-454C / R-455A



The SGD43S-M3-Sx can also be used as a sensor only

One product for both sensor and RDS applications

Cased coil



RDS Option 1: A2L Sensor + control board



RS-485

Mitigation
(+control) board

24V AC

+ daisy chain SGDs in large appliances
+ useful for location testing

contactors

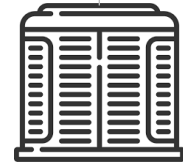
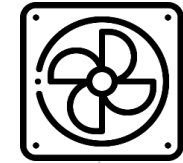
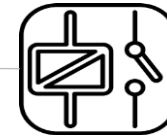

RDS Option 2: Integrated RDS



24V AC relay output

contactors

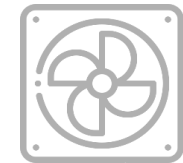

CHAPTER 3

Product Certification



Product certification

Sensor + mitigation board

- UL recognized RDS & sensor
 - RDS: [FTAM2 listing](#)
 - Sensor: [LZFE listing](#)
 - UL File # E537108
- The OEM does not need to get the RDS recognized, if using SGD43S-M3-Sx as an RDS
 - UL 60335-2-40 Annex LL
 - UL 60335-2-89 Annex LL
- The OEM only needs to perform location testing (A2L leak location), for the whole appliance
 - UL 60335-2-40 Annex MM
 - UL 60335-2-89 Annex LL



CHAPTER 4

Documentation



Documentation

- Available online on Sensirion.com:
 - [Datasheet SGD43S-M3-Sx](#)
 - [Starting guide](#)
 - [REACH-RoHS](#)
 - [Product Flyer](#)
 - [Design-in guide](#)
 - [Handling instruction](#)
 - [Multi-gas calibration application note](#)
 - [Packing specifications](#)

- Available on our partner's site:



Download the latest product launch package:

- Product description
- Links & documents
- Social media banners
- Pictures

SGD43S-M3-Sx

SGD43S-M3-Sx
Flexible and complete refrigerant leakage detection system

SENSIRION

Social media banner (add your logo)



SGD43S-M3-Sx space for partner logo

Introduction video & slides



Unboxing video

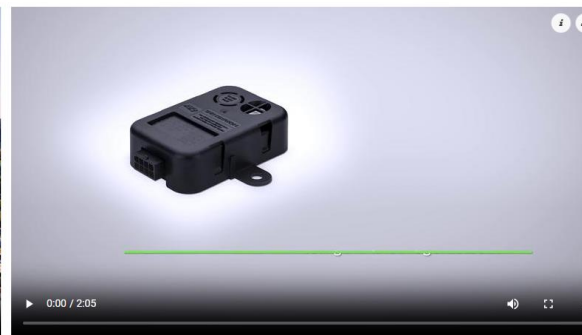

Pictures



STCC4 CO₂ SENSOR

Minimal Size. Maximize the Potential.

Maureen Rakotondraibe, Field Application Engineer

August 2025

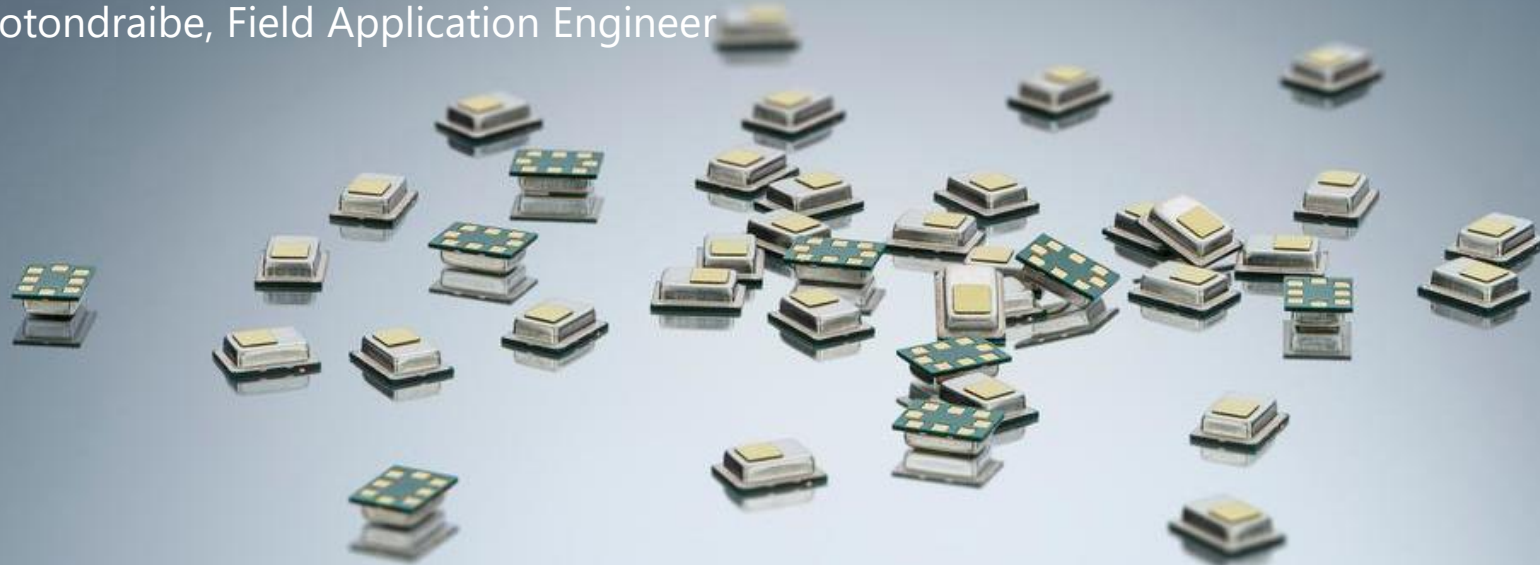

Presentation Topics



STCC4 Value Proposition



Key Considerations

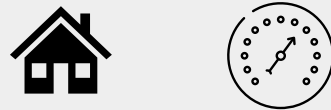

CO₂ Use Cases



Target Applications

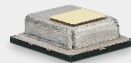
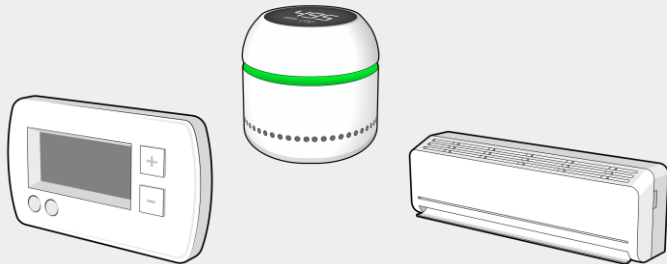

Fighting Guide

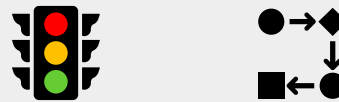

Resources



STCC4

Minimal Size. Maximize the Potential.

Striking the right balance between performance, size, power consumption and price.

50x
smaller form
factor than
SCD4x

$\pm(100\text{ppm}+10\%)$
optimized accuracy for
IAQ applications

Cost-efficiency
compared to optical
sensors

$<100\ \mu\text{A}$
possibility for
low power
applications

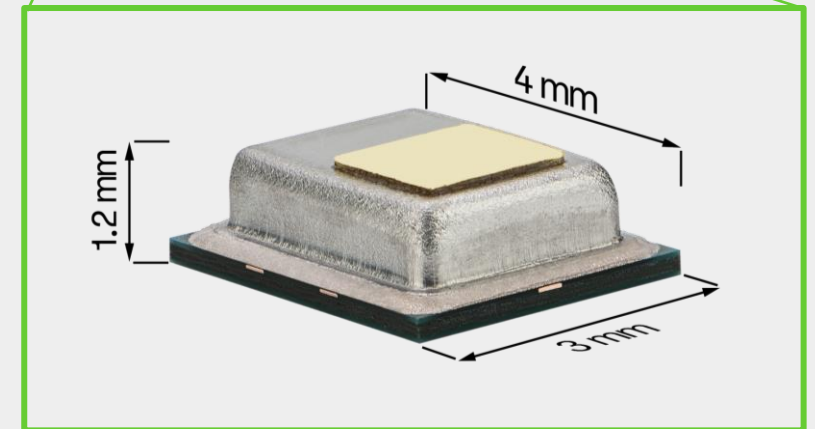

STCC4

We minimized the features.
You maximize the potential.

- Engineered and manufactured in Switzerland
- Two operation modes to meet different power budgets
- Dedicated I²C controller interface for SHT4x RHT compensation
- SMD assembly and tape & reel packaging enable high-volume applications



CHAPTER 4

STCC4 Technology

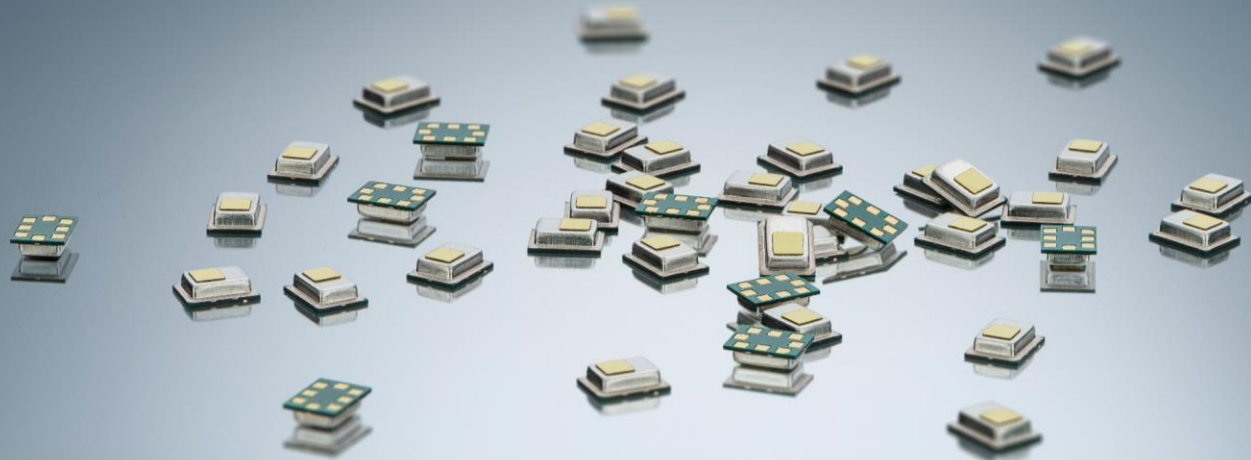

STCC4 Measurement Principle

Thermal Conductivity

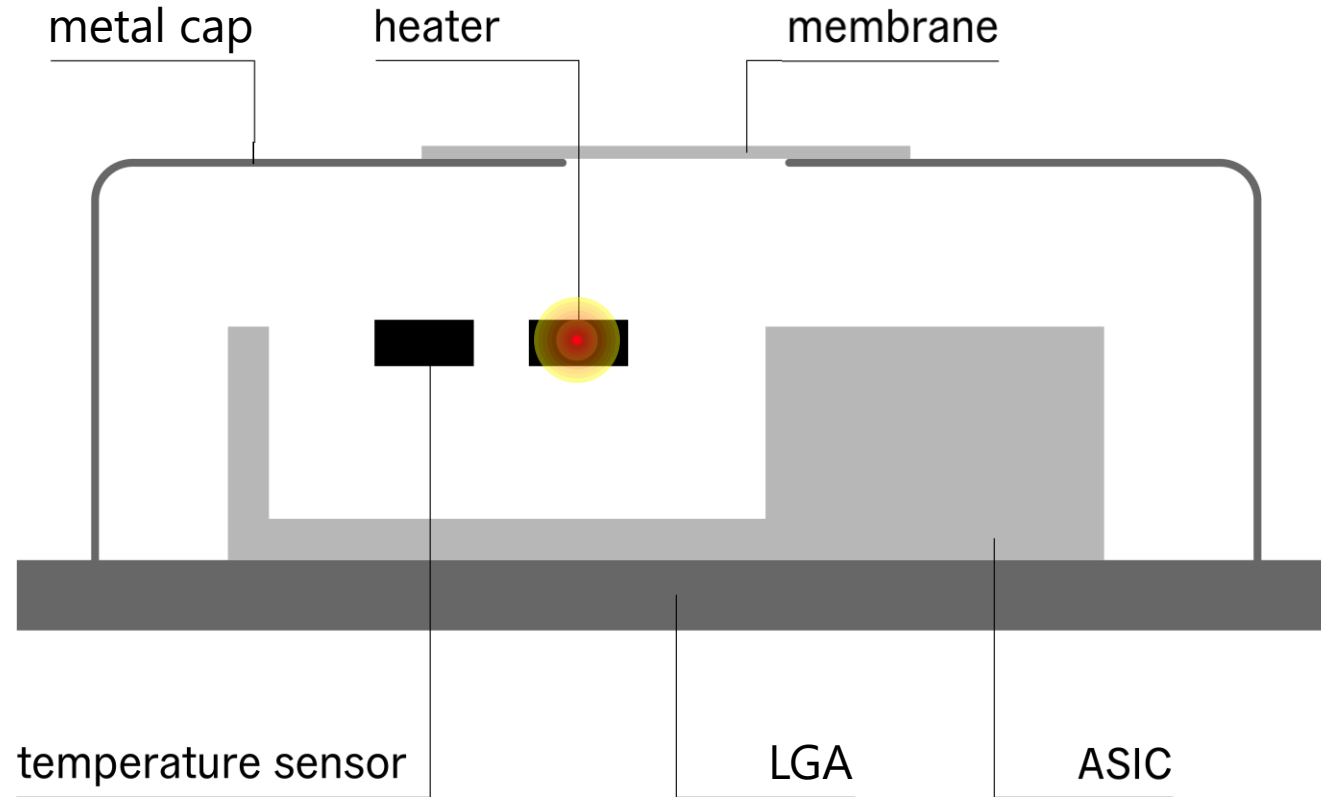

Based on CMOSens®

1. MEMS heater heats up gas in cavity of sensor
2. Heat in air conducts outward from heater
3. MEMS temperature sensor detects heat transferred through air
→ Measure thermal conductivity
4. Convert to CO₂ concentration based on ambient gas composition and environmental conditions

Key STCC4 Considerations

External Temperature and Humidity Compensation through SHT4x

✓ More flexible design-in possibilities

! Sensors should be nearby on PCB

✓ Customer pays only once for SHT4x

🪙 Cost-savings to optical CO₂ sensors

✓ Application circuit available to control SHT4x

Offer STCC4 + SHT4x Bundle to Customers!

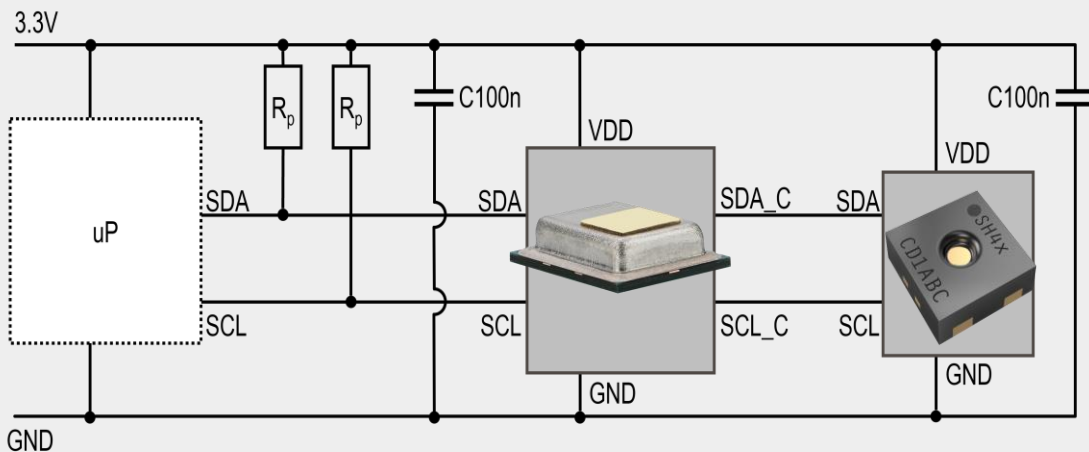

Regular Low CO₂ Concentration Exposure

✓ Ensures that automatic self-calibration (ASC) can maintain performance

≈ Similar to other optical CO₂ sensors



Target Indoor Environments

🏠 Indoor, stationary applications

➔ Small environmental changes

🚗 Mobile applications

📈 Complex environmental conditions

⛰️ High altitudes

! Add pressure sensor or convert from altitude

CHAPTER 3

STCC4 Use Cases and Applications

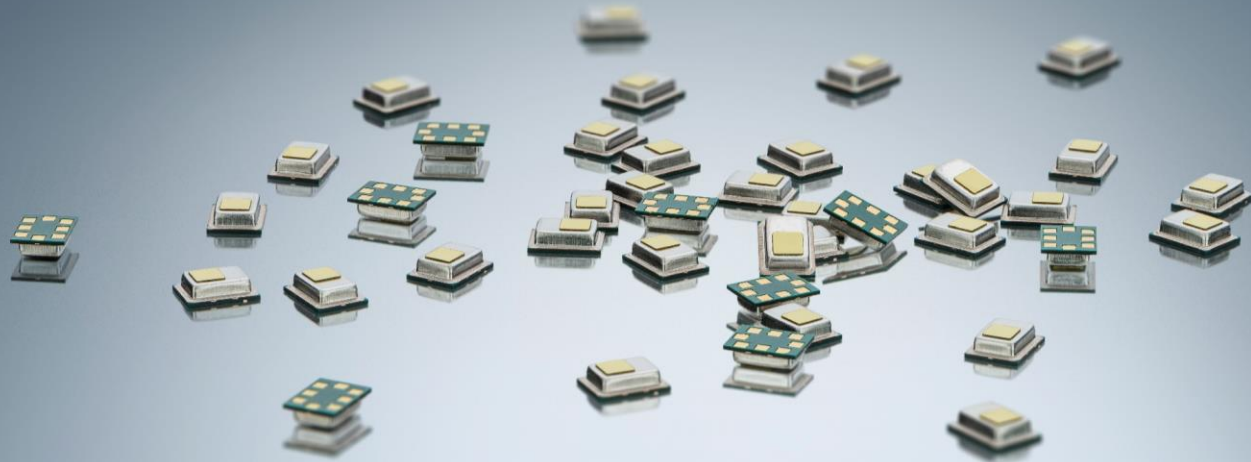



CO₂ Detection Use Cases

How CO₂ sensing can bring value to our customers

- **Healthy Indoor Environments**
High levels of CO₂ can lead to a reduced sleep quality as well as lower cognitive performance.
- **Viral Index**
Higher CO₂ concentrations have been shown to be correlated with a higher risk of infection.
- **Presence Detection Complement**
Anonymous and fast detection of CO₂ concentration can serve as a complement to traditional presence detectors.
- **Indoor Environment Changes**
Rapidly changing temperatures and decreasing CO₂ levels can indicate an open window or door.
- **Energy Efficiency**
Monitoring CO₂ levels can assist in ventilation optimization and lighting energy consumption.

SENSIRION

CO₂ is a Major Differentiator

Enabling New Use Cases at Home and at Work

Improve sleep quality

- **1000ppm CO₂** results in a significant worsening of sleep quality and higher stress levels after a night's rest¹
- **1300ppm CO₂** decreases deep sleep duration and causes a significant increase in salivary cortisol¹



¹ Kang, Mengyuan, et al. "Ventilation Causing an Average CO₂ Concentration of 1,000 Ppm Negatively Affects Sleep: A Field-Lab Study on Healthy Young People." *Building and Environment*, vol. 249, Elsevier BV, Feb. 2024, pp. 111118–18, <https://doi.org/10.1016/j.buildenv.2023.111118>. Accessed 25 Mar. 2024.

Reduce absenteeism

- **10-20%** increase in absence is associated with a corresponding CO₂ concentration of 1400ppm²
- **2 minutes** to breathe in a lungful of exhaled air from other occupants when indoor CO₂ concentration is above 1500 ppm



² Shendell, D. G., et al. "Associations between Classroom CO₂ Concentrations and Student Attendance in Washington and Idaho." *Indoor Air*, vol. 14, no. 5, Oct. 2004, pp. 333–41, <https://doi.org/10.1111/j.1600-0668.2004.00251>.

Enhance cognitive performance

- **21%** decrease in cognitive scores is observed with a 400ppm increase in CO₂ concentration³
- **101%** higher cognitive function scores in environments with low VOC, low CO₂ and high ventilation rates³



³ Allen, Joseph G., et al. "Associations of Cognitive Function Scores with Carbon Dioxide, Ventilation, and Volatile Organic Compound Exposures in Office Workers: A Controlled Exposure Study of Green and Conventional Office Environments." *Environmental Health Perspectives*, vol. 124, no. 6, June 2016, pp. 805–12, <https://doi.org/10.1289/ehp.1510037>.

STCC4 Target Applications

IAQM



Sleep monitors
Gadgets
Smart home devices

...

Building Control



Smart thermostat
Smart home devices
Lighting control

...

Appliance Opt.



Air purifiers
Air conditioners
Ventilation control

...

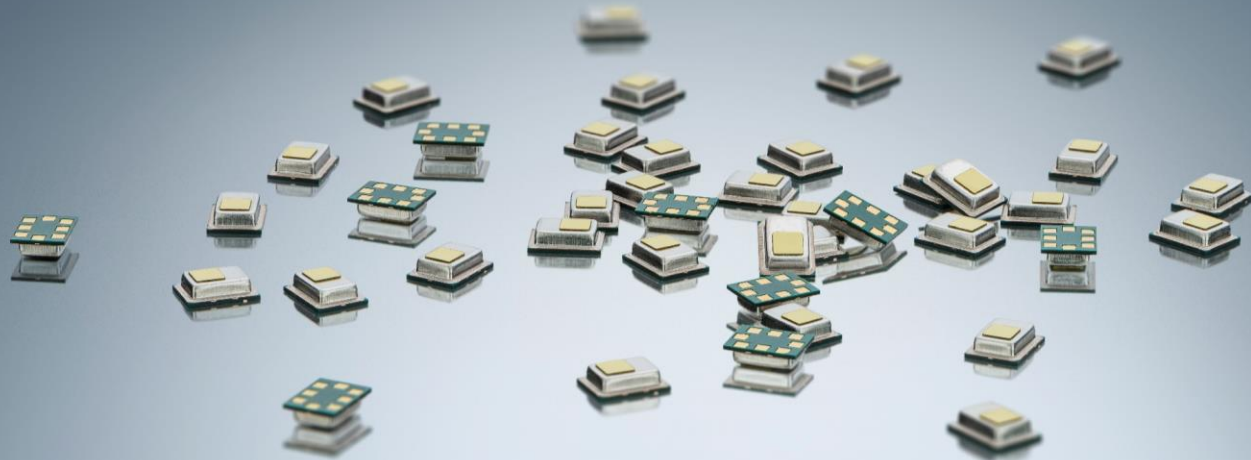

CHAPTER 3

STCC4 Fighting Guide

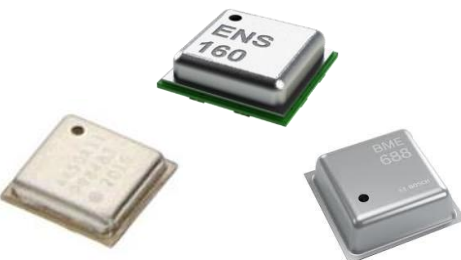

STCC4 Fighting Guide

Strategies for different scenarios

No CO ₂ Sensor	1. No environmental sensors 2. Only temperature and/or humidity sensing 	→ Introduce indoor air quality & energy efficiency with sensors → Fight with small size and small increase of BOM for large added value
eCO ₂ Sensor		→ Challenge concept of eCO ₂ : only correlation from H ₂ measurement! → Fight with direct CO ₂ sensing and lower power
Optical (NDIR/PA) CO ₂ Sensor		→ Highlight STCC4 advantages: smaller, lower power, lower price → Proactively guide CO ₂ sensor implementation: traffic light/IAQ algorithm

Yes, this is all Real CO₂

There is no alternative to a dedicated CO₂ sensor¹

CO₂ Measurements are Direct

- **Spectroscopy NDIR** measures how much infrared light is absorbed by CO₂ molecules
- **Photoacoustic PA NDIR** measures pressure waves generated by CO₂ molecules that absorbed infrared light
- **Thermal conductivity TC** measures changes in thermal conductivity in air due to CO₂ trends

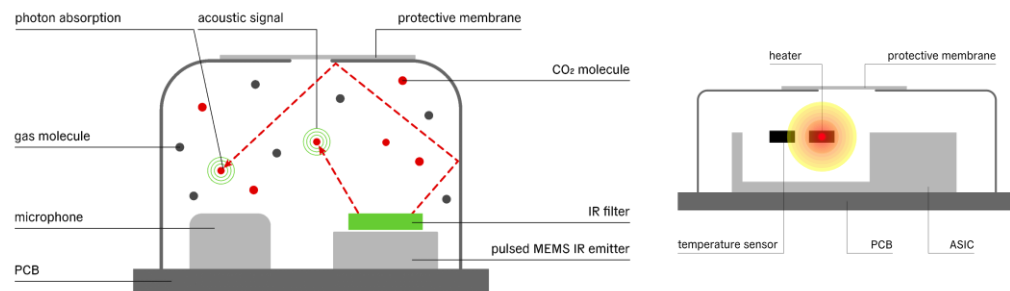

eCO₂ Measurements are a Derived Estimation

- **eCO₂** measurement is **derived from the reactions of all substances in air** through a MOx sensor
- **Key assumption** is that hydrogen (VOC produced by humans) is proportional to their exhaled CO₂
- Strong VOC events create **false positives**. $PCC^* < 0$ ⁽¹⁾ → flipping a coin would have produced a better result for the given test setting





*PCC = Pearson Correlation Coefficient

$$eCO_2 = f(\text{beer} + \text{perfume} + \text{paint} + \text{candle} + \text{cooking} + \text{person} + \dots)$$

¹Demanega, Ingrid, et al. "Performance Assessment of Low-Cost Environmental Monitors and Single Sensors under Variable Indoor Air Quality and Thermal Conditions." *Building and Environment*, vol. 187, Jan. 2021, p. 107415, <https://doi.org/10.1016/j.buildenv.2020.107415>. Accessed 28 June 2021.

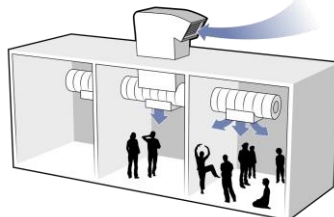
CO₂ Sensor Implementation

Guiding customers to maximize sensor value

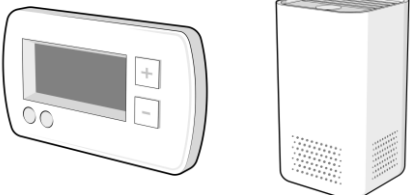
Implementation Methods	Example Applications
<p>ppm output</p> <ul style="list-style-type: none">• Nonintuitive for consumers• May be required in regulated applications• Best suited for SCD30/SCD4x	<p data-bbox="1082 564 1235 706"></p> <p data-bbox="1286 614 1745 664">Commercial DCV/ERV</p> <p data-bbox="1898 521 2229 735"></p>
<p>Traffic light</p> <ul style="list-style-type: none">• Intuitive for consumers• Good match with STCC4	<p data-bbox="1082 771 1235 913"></p> <p data-bbox="1286 821 1847 871">Indoor air quality monitors</p> <p data-bbox="2025 763 2165 921"></p>
<p>IAQ index/feedback loop</p> <ul style="list-style-type: none">• Highest value of STCC4 output for:<ul style="list-style-type: none">• Customer• Consumer	<p data-bbox="1082 978 1235 1120"></p> <p data-bbox="1286 1035 1796 1085">Appliances, thermostats</p> <p data-bbox="1860 963 2267 1156"></p>

CHAPTER 3

STCC4 Evaluation and Documentation

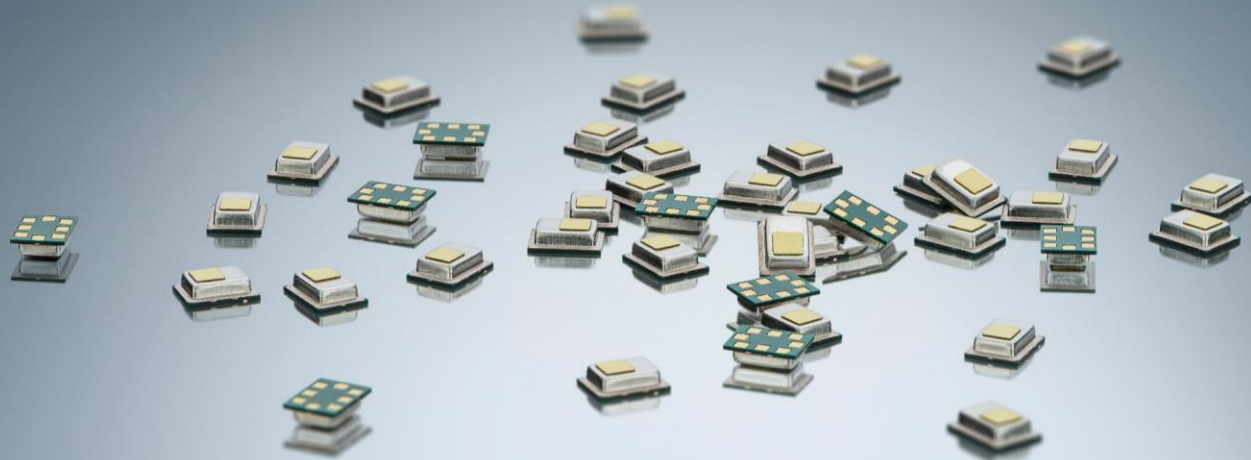

STCC4 Evaluation Kit

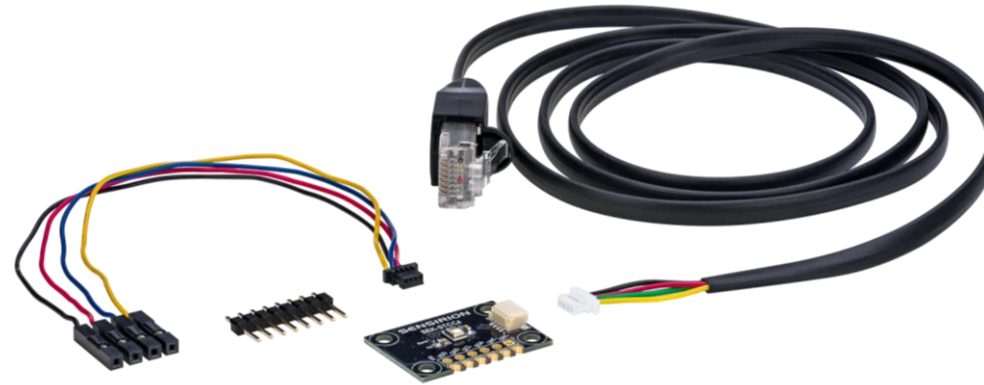

SEK-STCC4-Sensor



SEK-SensorBridge

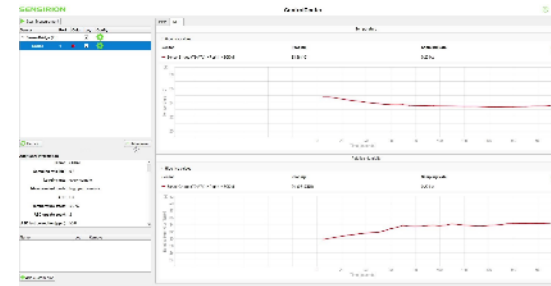

Control Center

Drivers available on Github

STCC4 NPI Documentation

Introduction

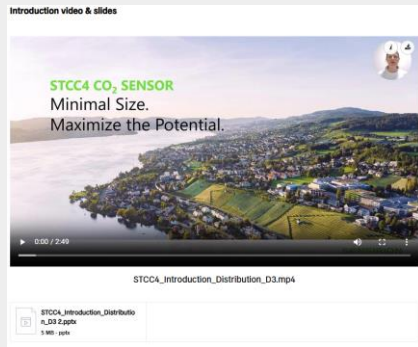

Product Description

Product description (EN/DE/CN/JP/KO)

Sensirion_product description_STCC4_EN.docx 156 KB - docx	Sensirion_product description_STCC4_DE.docx 175 KB - docx	Sensirion_product description_STCC4_CN.docx 152 KB - docx
Sensirion_product description_STCC4_JP.docx 156 KB - docx	Sensirion_product description_STCC4_KO.docx 156 KB - docx	

Product Documents

Links & documents

[STCC4 product page](#)[SEK-STCC4 product page](#)[Datasheet](#)[REACH & RoHS declaration](#)[One-pager smart thermostats](#)[Carbon Dioxide product flyer](#)[Indoor air quality brochure](#)

Product Pictures



Evaluation Kit Support

Start prototyping

Find everything you need here.

- [Product description](#)
- [Tutorials](#)
- [Drivers](#)
- [Resources](#)

Evaluate without writing code

In just three simple steps, you will be collecting valuable data without needing any coding or soldering skills.

How it works

1. Order a SEK-SensorBridge and a SEK-STCC4 via our distribution network.
2. Download the SEK-CarbonDioxide.sensirion software (available for Windows, Linux and MacOS).
3. Connect the STCC4 development board to your computer by using a SEK-SensorBridge and start measuring.

Key Takeways

STCC4 Value Proposition

Unmatched form factor 

\$ Cost-efficiency

Low power 

 Optimized accuracy

Key Considerations



SHT4x RHT compensation 

 Regular low CO₂ events

Indoor, stationary applications 

 Recommend pressure input

CO₂ Use Cases

 Healthy indoor environments 

Assist presence detection 

 Energy efficiency

Target Applications

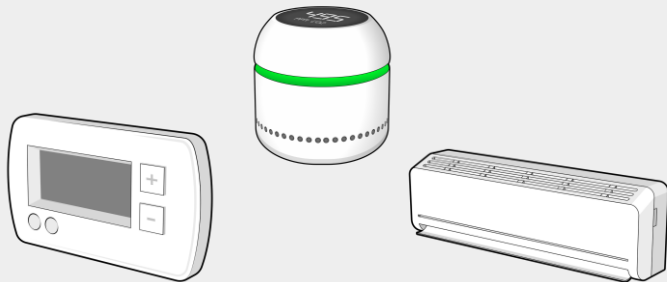

Fighting Guide

Why not CO₂? 

Use STCC4, not eCO₂

Maximize sensor value 

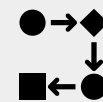

Resources

Evaluation Kit 

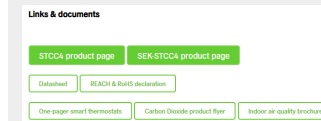

NPI Documentation



TIME FOR Q&A!

Kahoot!

1. Scan the QR code and enter the PIN on the screen

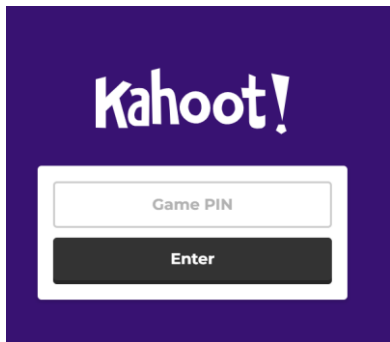

2. Enter your NAME and SURNAME and wait for the quiz to start

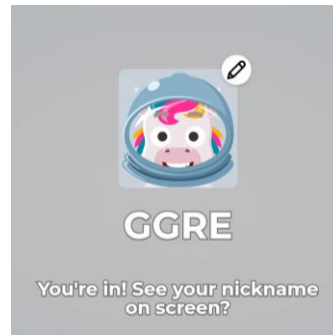
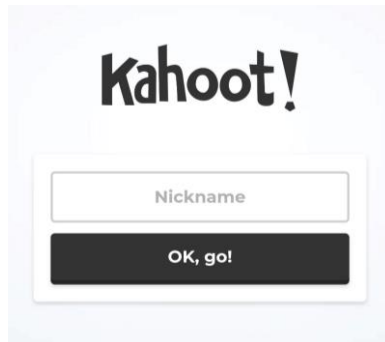

3. Test yourself!
Your score is based on how fast you are and if the answer is correct or not

The question and the answers will be visualized on the screen

Click on the symbol corresponding to the correct answer

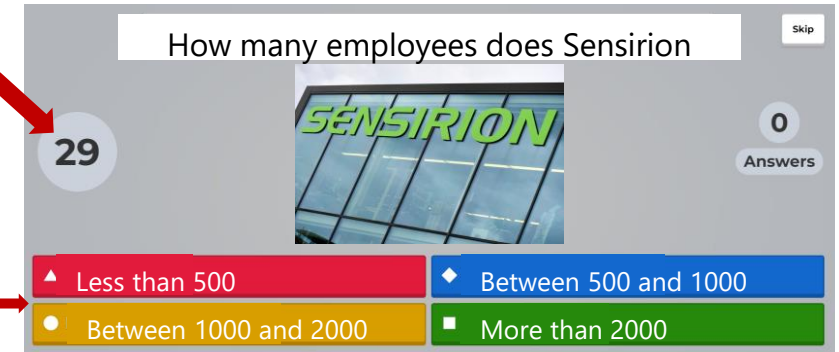
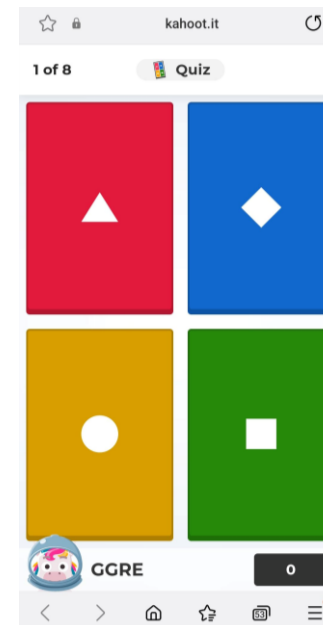

4. Enjoy it!

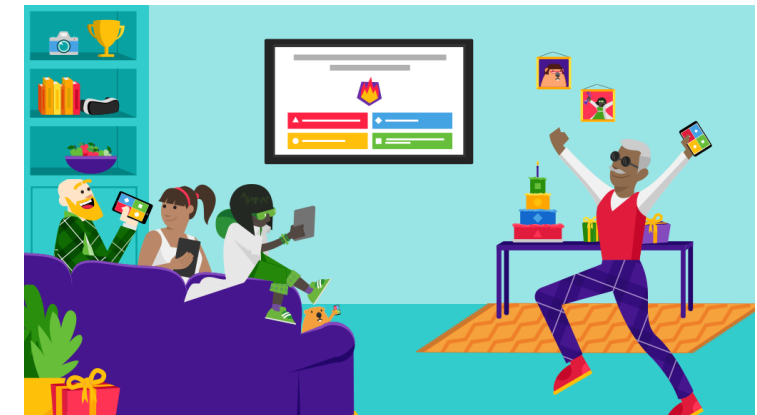

SENSIRION

SENSIRION