

SHT4x – Market Leading Humidity & Temperature Sensor

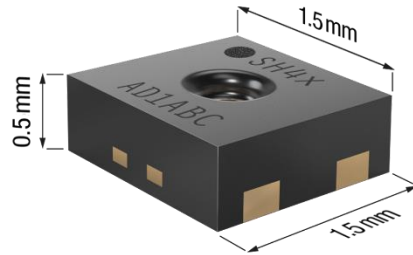

SHT4x

Unique Selling Points

- Technology and Market leader for 20 yrs.
- Lowest power consumption
- Specialized product variants for various markets & applications

How to Evaluate



SEK-SHT40

SEK-SHT40I

Breakout Boards:



Adafruit SHT40MikroElektronika Temp&Hum 15
[Click](#)



SEK-Sensorbridge

Useful Links

Basic Documents

- [Datasheet SHT4x](#)
- [Datasheet SHT4xl-Digital](#)
- [SHT Handling Instructions](#)
- [SHT Design-In Guide](#)

Drivers & Tools

- [Embedded Drivers SHT](#)
- [SW ControlCenter](#)

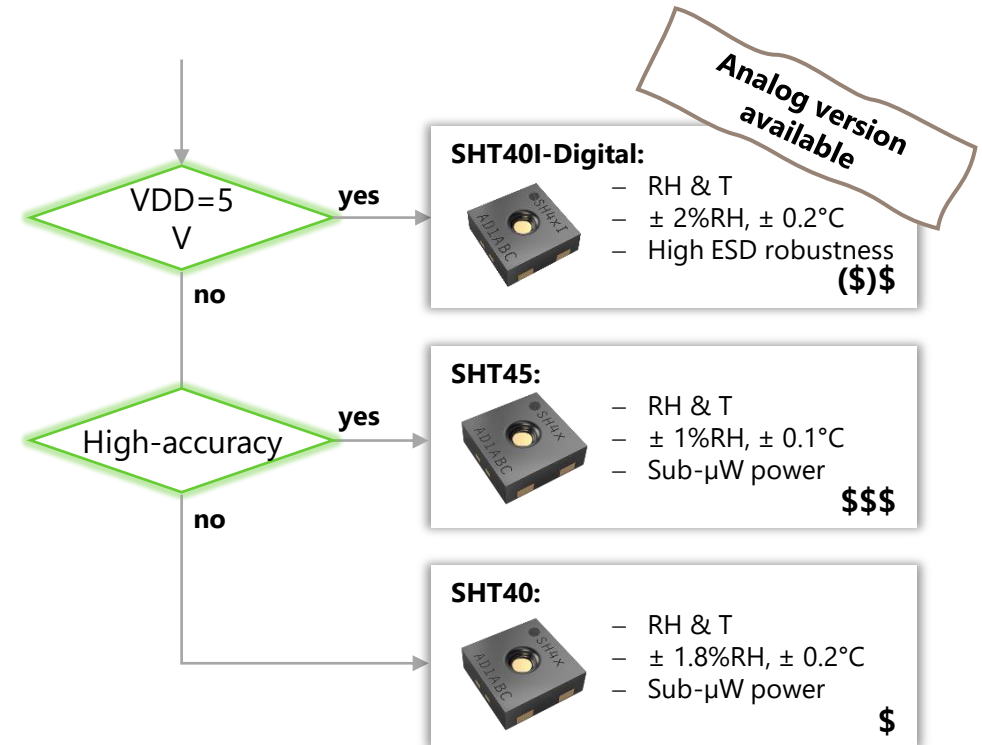

SHT4x: "mature 4th generation, highest volume technology from market leader. Available in different accuracy gradings, delivering sub-µW power consumption."

SENSIRION

www.sensirion.com