

Datasheet – SLF3S-xxxxD

Sensirion CMOSens® Liquid Flow Sensing for Manifold Integration



Highlights

- Downmount mounting for manifold integration
- Flow sensing up to ± 2 ml/min or ± 40 ml/min
- Calibrated for H₂O and IPA
- Temperature compensated
- Turn down ratio beyond 200:1
- Response time below 20 ms

The SLF3S series from Sensirion is a compact liquid flow sensor for high-volume applications, offering accurate bidirectional flow measurement. It features a downmount design for easy manifold integration and a digital I²C interface via a 6-pin connector. Built on Sensirion’s CMOSens® technology, it integrates sensing, signal processing, and calibration on a single chip, enabling high performance, reliability, and efficient mass production, ideal for demanding OEM applications.

Device Overview

Product	Details
SLF3S-0600D	± 2 ml/min H ₂ O flow rate
SLF3S-1300D	± 40 ml/min H ₂ O flow rate

Contents

1	SLF3S-0600D Sensor Performance	3
1.1	Flow Rate Specification Charts for SLF3S-0600D	4
2	SLF3S-1300D Sensor Performance	5
2.1	Flow Rate Specification Charts for SLF3S-1300D	6
3	Specifications.....	7
3.1	Thermal Conductivity Specifications	7
3.2	Electrical Specifications.....	7
3.3	Timing Specifications.....	7
3.4	Absolute Minimum and Maximum Ratings.....	8
3.5	Pin Assignment	8
3.6	Fluidic Specifications and Connections.....	9
3.7	Mechanical Specifications.....	9
4	Sensor Output Signal Description.....	11
4.1	Flow Rate Measurement.....	11
4.2	Temperature Measurement	12
4.3	Thermal Conductivity Measurement	12
4.4	Signaling Flags and Extended Features.....	12
4.5	Sensor Start-Up and Warm-Up Behavior	13
4.6	New data interrupt – IRQn Functionality.....	13
5	Digital Interface Description.....	14
5.1	I ² C Address.....	14
5.2	I ² C Sequences	14
5.3	I ² C Commands.....	14
5.4	Checksum Calculation	18
5.5	Conversion to Physical Values	18
6	Ordering Information.....	19
7	Packaging Information	19
8	Revision History.....	20

1 SLF3S-0600D Sensor Performance

The following Table 1 and **Error! Reference source not found.** list the specifications of the SLF3S-0600D liquid flow sensors. The products come fully calibrated for water (H₂O) and Isopropyl alcohol (IPA).

Parameter	SLF3S-0600D	Unit
H2O Full scale flow rate	±2 000	ul/min
H2O Sensor output limit ¹	±3 250	ul/min
Accuracy (whichever error is larger)	±5	% of measured value
	5	ul/min
Repeatability (whichever error is larger)	±0.5	% of measured value
	0.5	ul/min
Temperature coefficient ² (additional error / °C; whichever is larger)	0.2	% measured value / °C
	0.02	ul/min / °C
Mounting orientation sensitivity ³	<0.5	ul/min

Table 1. Specifications for liquid flow sensors SLF3S-0600D (all data for H₂O, at 23 °C, and for V_{DD} 3.5 V).

Parameter	SLF3S-0600D	Unit
IPA Full scale flow rate	±2 000	ul/min
IPA Sensor output limit ¹	±3 250	ul/min
Accuracy (whichever error is larger)	±10	% of measured value
	10	ul/min
Repeatability (whichever error is larger)	±0.5	% of measured value
	0.5	ul/min
Temperature coefficient ² (additional error / °C; whichever is larger)	0.2	% measured value / °C
	0.1	ul/min / °C
Mounting orientation sensitivity ³	<2	ul/min

Table 2. Specifications for liquid flow sensors SLF3S-0600D (all data for IPA, at 23 °C, and for V_{DD} 3.5 V).

¹ Flow rate at which the sensor output saturates. See section **Error! Reference source not found.** for performance between full scale and saturation point.

² Additional accuracy error in case liquid and ambient temperatures are similar but both deviating from 23 °C.

³ Maximum additional error when flow channel is vertical.

1.1 Flow Rate Charts for SLF3S-0600D

The SLF3S-0600D liquid flow sensors show bi-directional, linear transfer characteristics. The products come fully calibrated for water (H₂O) and Isopropyl alcohol (IPA).

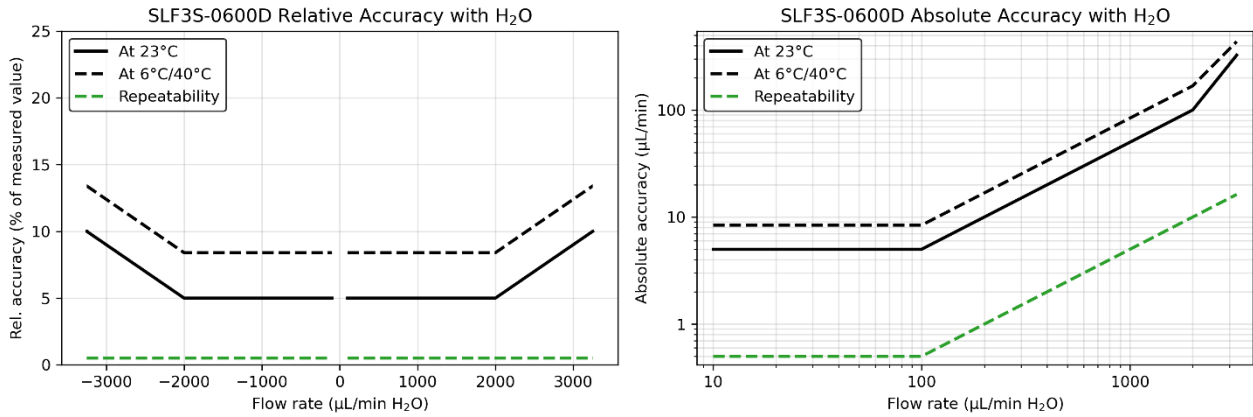

Figure 1. Left: Liquid flow sensor accuracy and repeatability across the flow range of the SLF3S-0600D. Relative error in ±% of measured value for H₂O. **Right:** Liquid flow sensor accuracy and repeatability across the positive flow range of the SLF3S-0600D. Absolute error in ml/min for H₂O.

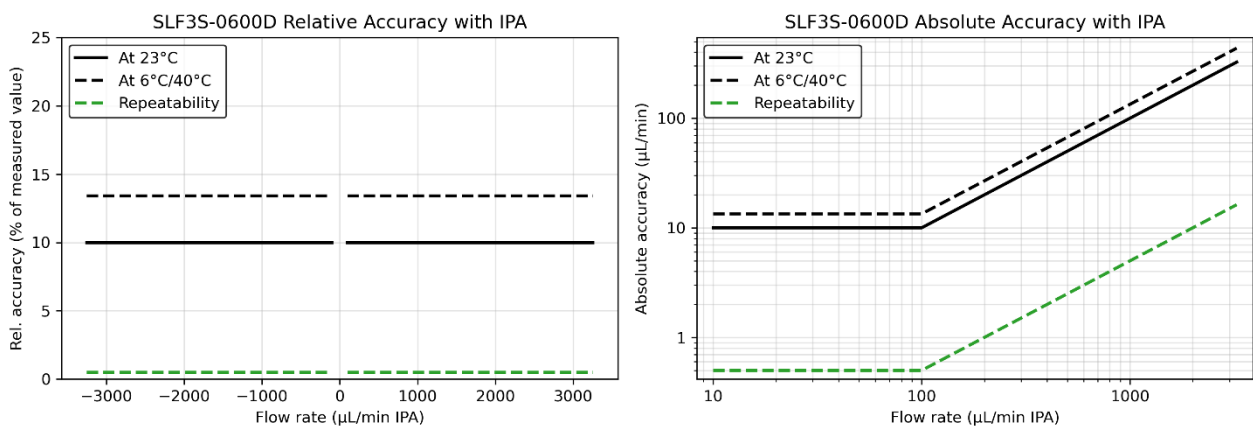

Figure 2. Left: Liquid flow sensor accuracy and repeatability across the flow range of the SLF3S-0600D. Relative error in ±% of measured value for IPA. **Right:** Liquid flow sensor accuracy and repeatability across the positive flow range of the SLF3S-0600D. Absolute error in ml/min for IPA.

2 SLF3S-1300D Sensor Performance

The following Table 3 and Table 4 list the specifications of the SLF3S-1300D liquid flow sensor. The product comes fully calibrated for water (H₂O) and Isopropyl alcohol (IPA).

Parameter	SLF3S-1300D	Unit
H ₂ O Full scale flow rate	±40 000	µl/min
H ₂ O Sensor output limit ⁴	±65 000	µl/min
Accuracy ⁵ (see Figure 1)	-40 < ml/min < -20	±10 to ±25 % of measured value
	-20 < ml/min < -1	±5 to ±10 % of measured value
	-1 < ml/min < 1	50 µl/min
	1 < ml/min < 20	±5 % of measured value
	20 < ml/min < 40	±5 to ±10 % of measured value
Repeatability (whichever error is larger)	±0.5	% of measured value
	10	µl/min
Temperature coefficient ⁶ (additional error / °C; whichever is larger)	0.3	% of measured value / °C
	2	µl/min / °C
Mounting orientation sensitivity ⁷	<20	µl/min

Table 3. Specifications for liquid flow sensors SLF3S-1300D (all data for H₂O, at 23 °C, and for V_{DD} 3.5 V).

Parameter	SLF3S-1300D	Unit
IPA Full scale flow rate	±40 000	µl/min
IPA Sensor output limit ⁴	±65 000	µl/min
Accuracy ⁵ (whichever error is larger)	±10	% of measured value
	200	µl/min
Repeatability (whichever error is larger)	±0.5	% of measured value
	10	µl/min
Temperature coefficient ⁶ (additional error / °C; whichever is larger)	0.2	% of measured value / °C
	4	µl/min / °C
Mounting orientation sensitivity ⁷	<50	µl/min

Table 4. Specifications for liquid flow sensors SLF3S-1300D (all data for IPA, at 23 °C, and for V_{DD} 3.5 V).

⁴ Flow rate at which the sensor output saturates. See section 2.1 for performance between full scale and saturation point.

⁵ For SLF3S-1300D, the performance is lower at higher flows and in the reverse direction. See section 2.1 for detailed specifications.

⁶ Additional accuracy error in case liquid and ambient temperatures are similar but both deviating from 23 °C.

⁷ Maximum additional error when flow channel is vertical.

2.1 Flow Rate Charts for SLF3S-1300D

The SLF3S-1300D liquid flow sensors show bi-directional, linear transfer characteristics. The products come fully calibrated for water (H₂O) and Isopropyl alcohol (IPA).

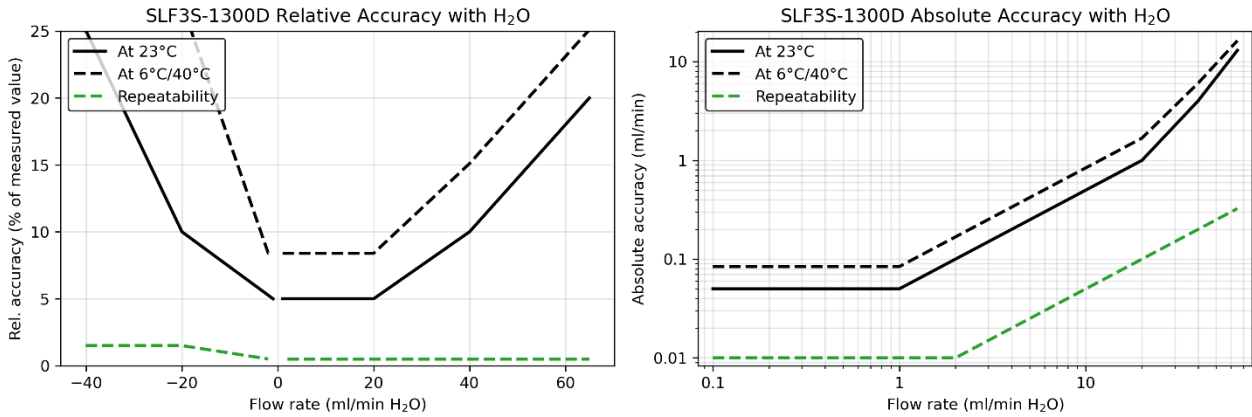

Figure 3. Left: Liquid flow sensor accuracy and repeatability across the flow range of the SLF3S-1300D. Relative error in $\pm\%$ of measured value for H₂O. **Right:** Liquid flow sensor accuracy and repeatability across the positive flow range of the SLF3S-1300D. Absolute error in ml/min for H₂O.

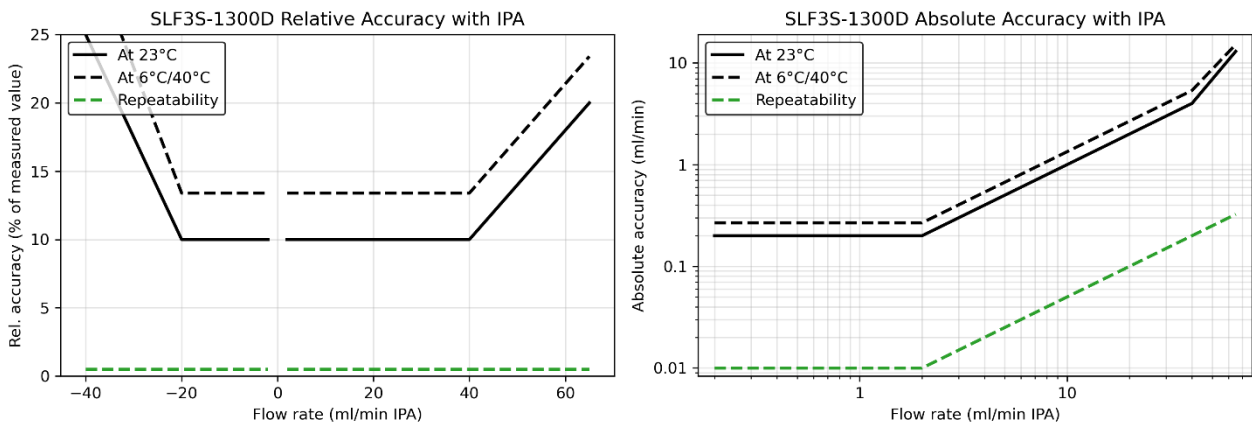

Figure 4. Left: Liquid flow sensor accuracy and repeatability across the flow range of the SLF3S-1300D. Relative error in $\pm\%$ of measured value for IPA. **Right:** Liquid flow sensor accuracy and repeatability across the positive flow range of the SLF3S-1300D. Absolute error in ml/min for IPA.

3 Specifications

3.1 Thermal Conductivity Specifications

The following Table 5 lists the specifications of the thermal conductivity feature for the SLF3S-xxxxD sensors. To use the feature, the flow needs to be stopped (zero flow condition).

Parameter	SLF3S-0600D	Unit
Output for air	100	a.u.
Output for water	10'000	a.u.
Maximum expected drift over lifetime	400	a.u.
Repeatability	30	a.u.

Table 5. Specifications for thermal conductivity measurements with SLF3S-xxxxD liquid flow sensors (all data for V_{DD} 3.5 V and at 23°C).

3.2 Electrical Specifications

Parameter	Symbol	Conditions	Min.	Typical	Max.	Units
Supply voltage DC	V _{DD}		3.2	3.5	3.8	V
Power-up/down level	V _{POR}		2.3	2.5	2.7	V
Supply current	I _{DD}	Measurement		4.5	6	mA
		Idle mode		0.05	0.6	mA

Table 6. Electrical characteristics.

3.3 Timing Specifications

Parameter	Symbol	Min.	Typical	Max.	Units	Comments
Power-up time	t _{PU}			25	ms	Time to sensor ready
Soft reset time	t _{SR}			25	ms	Time between soft reset command and sensor ready
Warm-up time	t _w		50 (-1300D) 60 (-0600D)		ms	Time needed until sensor output is within specification according to section Error! Reference source not found. at 50% full scale flow rate.
I ² C SCL frequency	f _{I2C}		400	1000	kHz	
Update rate liquid flow value and High Flow flag	f _{flow}	1800	2000	2200	Hz	
Update rate temperature value and Air-in-Line flag	f _{temp}	73	83	111	Hz	
Recommended sensor read out frequency	f _{ro}	10	50-200	2000	Hz	Recommendations are based on explanations in section Error! Reference source not found.

Table 7. Timing specifications.

3.4 Absolute Minimum and Maximum Ratings

Stress levels beyond those listed in Table 8 may cause permanent damage to the sensor or affect its reliability. These are stress ratings only and functional operation of the sensor at these conditions is not guaranteed. Ratings are only tested each at a time.

Parameter	Rating	Unit
Operating temperature	+5 ... +50	°C
Maximum relative humidity for long-term exposure	40°C dew point or 95 %RH, whichever is lower; non-condensing	n/a
Short term storage temperature ⁸	-20 ... +60	°C
Short term storage humidity ⁸	0...95 %RH; non-condensing	% RH
ESD HBM (human body model)	< 2 (class 1C)	kV
Supply voltage V _{DD}	-0.3 to 5.5	V

Table 8. Absolute minimum and maximum ratings.

ESD Warning: The sensor is susceptible to ESD damage, especially when touching the connector pins. During handling and testing, suitable ESD precautions must be taken.

Please note that the sensor chip is not electrically isolated from the flow channel and the medium passing through it. Therefore, a voltage difference between sensor and medium should be avoided at all times through proper system grounding and design.

3.5 Pin Assignment

The liquid flow sensor is equipped with a 6-pin connector (Molex part number: 53261-0671; 1.25 mm pitch PicoBlade header, 6 circuits) for electrical connection, see Table 9 for the pin assignment. The sensor is compatible with the mating standard connector (Molex part number 51021-0600) and the PicoBlade Standard Cable Assembly series 15134-06xx (PicoBlade-to-PicoBlade cable assembly, available in different lengths). These parts can be ordered from the usual electronics on-line distributors.

Pad	Description	Comments
1	IRQn	Connect to the micro controller if I2C-address change (see 5.1) or data interrupt (see 4.5) is needed. Otherwise connect to GND or leave floating
2	SDA (data)	Serial data, bidirectional
3	VDD	Supply voltage
4	GND	Ground
5	SCL (clock)	Serial clock, bidirectional
6	n.c.	Nonfunctional, leave floating

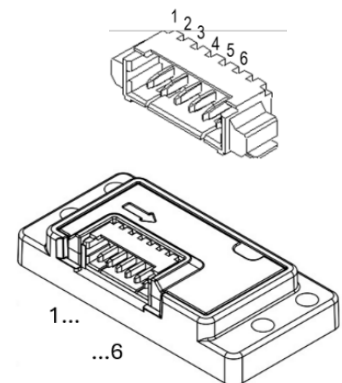

⁸ Flow path empty. Short term storage refers to temporary conditions during e.g. transport.

Table 9: Pin assignment.

3.6 Fluidic Specifications and Connections

Parameter	SLF3S-0600D	SLF3S-1300D
Wetted materials	Polyphenylene sulfide (PPS), stainless steel 316L, epoxy-based adhesive	
Fluidic connector ports (fittings)	Downmount, Φ 1.1mm	Downmount, Φ 1.7 mm
Recommended channel diameter	1.0 mm	1.8 mm
Recommended mounting screws	M2 (4 pcs)	
Recommended o-rings	1.5 x 1.0 mm (2pcs)	2.5 x 1.0 mm (2pcs)
Pressure drop (H ₂ O, 23 °C)	< 4 mbar at 2 ml/min	< 4.5 mbar at 40 ml/min

Table 10. Fluidic specifications and connections.

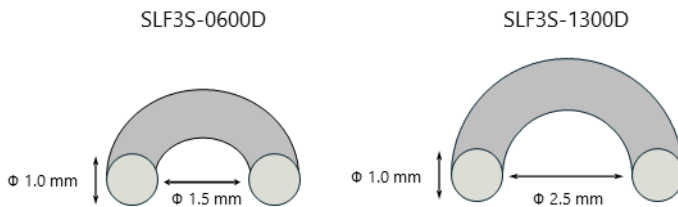

Figure 5. Recommended o-ring dimensions for SLF3S-0600D and -1300D.

3.7 Mechanical Specifications

Parameter	SLF3S-0600D	SLF3S-1300D
Largest dimensions	~ (30.0 x 15.0 x 6.5) mm ³	
Weight	2.1 g	
Inner diameter	~1 mm	~ 2 mm
Inner volume	~20 ul	~ 63 μ l
Maximum recommended operating pressure ⁹	12 bar	8 bar
Rated burst pressure ⁹	25 bar	25 bar

Table 11. Mechanical specifications.

⁹ Pressure ratings at 23°C, apply to sensor only; pressure rating of the fitting interface has to be assessed separately.

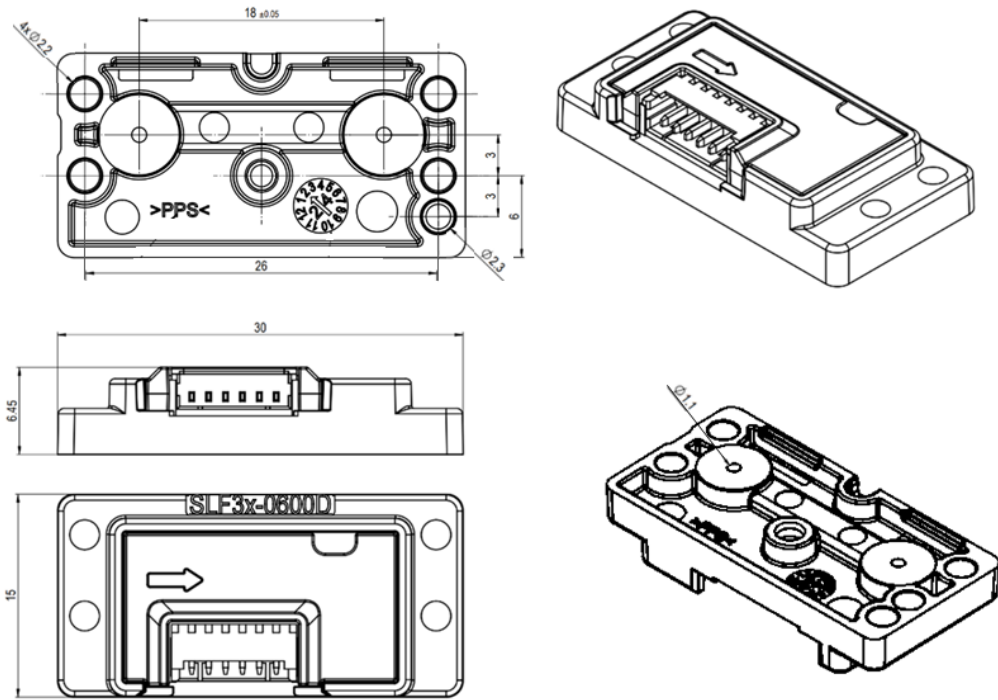

Figure 6. Dimensions of SLF3S-0600D (all dimensions in mm).

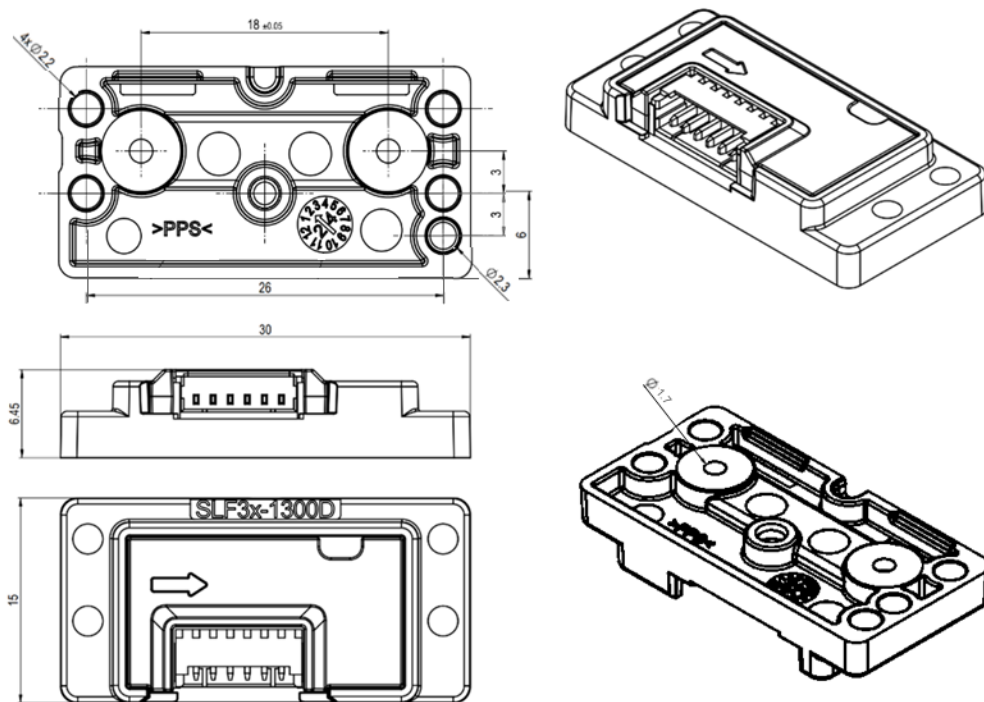

Figure 7. Dimensions of SLF3S-1300D (all dimensions in mm).

3.7.1 Mechanical Mounting

The SLF3S-xxxxD sensors are designed to be mounted onto a manifold. The manifold needs to have a circular cut-out for o-rings, which are used to seal the assembly. Four M2 screws are used to secure the sensor at the manifold. Figure 8 shows a sample manifold design. The component pictured below is also a part of SLF3S-xxxxD evaluation kit. CAD files are available on Sensirion website.

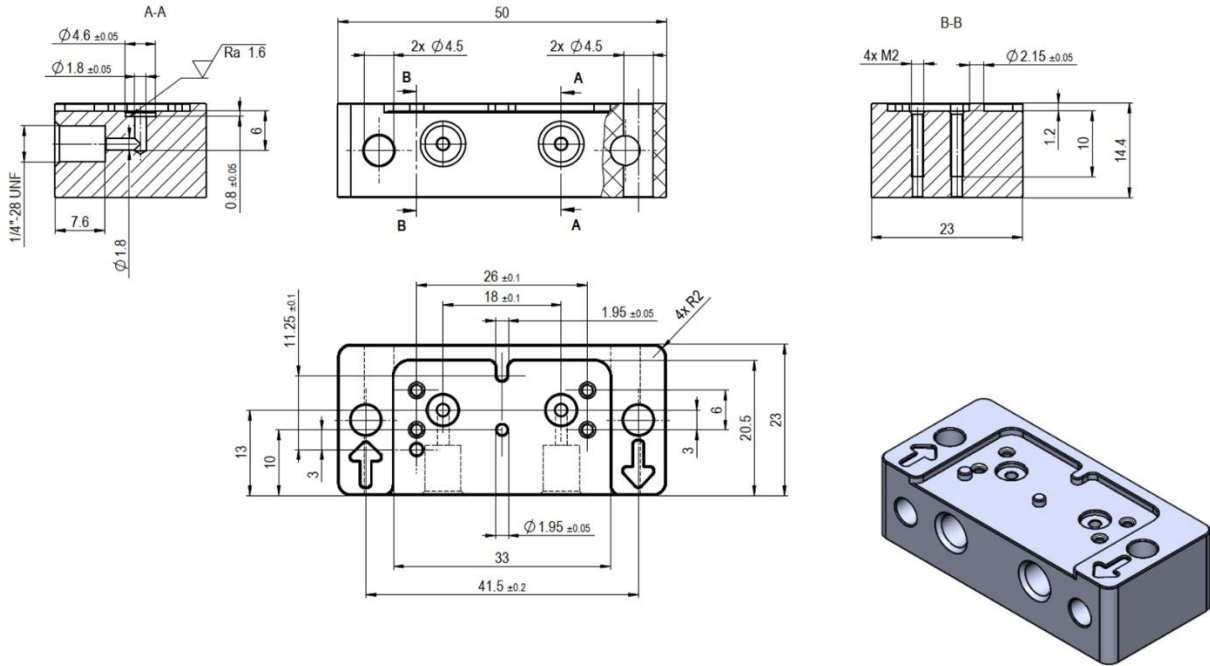

Figure 8. Sample manifold design for SLF3S-1300D sensor. The part pictured is also available as part of the evaluation kits for both SLF3S-0600D and -1300D. If designing a manifold mount for -0600D we recommend changing the dimensions of the manifold ports according to Table 10. All dimensions in mm.

4 Sensor Output Signal Description

4.1 Flow Rate Measurement

After receiving the *Start Continuous Measurement* command, the sensor enters continuous measurement mode. Measurements are performed with a duration of ~0.5 ms, resulting in a flow rate update every 0.5 ms (see Table 7). The reported flow rate corresponds to the average value \bar{x} of all individual measurements x_i acquired since the last readout. This allows the sensor to be read at arbitrary intervals without loss of information and prevents aliasing.

For readout intervals shorter than 100 ms, the output is calculated as the arithmetic mean:

$$\bar{x} = \sum_{i=1}^N \frac{x_i}{N} \quad \text{for } t < 100 \text{ ms}$$

where N is the number of samples since the last readout.

For readout intervals exceeding 100 ms, the sensor applies exponential smoothing with a smoothing factor $\alpha = 0.0125$:

$$S_k = \alpha \cdot x_i + (1 - \alpha) \cdot S_{k-1}, \quad S_0 = \bar{x}, \quad \text{for } t > 100 \text{ ms}$$

where the output flow rate corresponds to the most recent value S_k . With $\alpha = 0.0125$, the output represents an effective averaging window of approximately 100 ms.

To avoid information loss, the sensor should be read at intervals not exceeding 100 ms. When exponential smoothing is active, this is indicated by bit 5 of the signaling flags being set to 1 (see Section 5.3.1).

4.2 Temperature Measurement

Temperature is measured every ~12 ms (see Table 7) using an integrated temperature sensor. The reported value corresponds to the most recent measurement. The measured temperature reflects the sensor's internal temperature, which depends on ambient conditions, fluid temperature, and operating conditions. No averaging is applied to the temperature output.

4.3 Thermal Conductivity Measurement

The SLF3S sensors can operate in a dedicated mode to measure the thermal conductivity of the medium within the sensor. At zero flow, heat dissipation from the integrated microheater is governed by the thermal conductivity of the medium: higher conductivity results in increased heat transfer and a lower heater temperature. The sensor reports thermal conductivity in arbitrary units, scaled such that air corresponds to 100 and water to 10,000. These values provide an approximate indication of the medium's thermal conductivity. The application note *Thermal Conductivity Measurement* describes how to use this feature.

4.4 Signaling Flags and Extended Features

The SLF3S sensors provide several signaling flags (see Table 14), enabling detection of fault conditions such as air-in-line events and flow rates exceeding the sensor's output limits. Another flag indicates whether exponential smoothing is applied to the flow rate data (see Section 4.1).

The fault detection flags, Air-in-Line and High Flow, indicate whether such events have occurred at least once since the last readout. For example, if the sensor is read after a 50 ms interval, the corresponding flag will reflect whether the event occurred during that period.

4.4.1 Detection of High Flow Rates

During operation, flow rates may exceed the sensor's specified output limit (e.g., during priming or flushing). While this does not damage the sensor (provided maximum pressure limits are not exceeded), it may lead to saturation or invalid flow readings. To indicate such conditions, bit 1 of the signaling flag output is set to high (= 1), and it stays high until it is read out (see Table 14).

4.4.2 Detection of Air-in-Line

Due to the thermal measurement principle, the sensor can distinguish between liquid and air within the flow channel. When air is passing through the sensor, the bit 0 of the signaling flag output is set to high (= 1), and it stays high until it is read out (see Table 14). Air bubbles may temporarily affect the flow profile, which can also trigger the High Flow flag at the beginning or end of the bubble passage.

Please note that due to the complex cross section of the flow channel in SLF3S-1300D, the air-in-line functionality, only detects bubbles which are similar in size to the full cross-section of the channel or when there is no liquid inside the sensor. Detection of smaller bubbles may be unreliable. The SLF3S-0600D is not affected by these limitations.

4.5 Sensor Start-Up and Warm-Up Behavior

The maximum time for system power-up is 25 ms until the sensor responds to communication requests. After reset or start-up of the sensor, the sensor’s internal heater is turned off and must be started by performing a *Start Continuous Measurement* command (see section 5.3.1). The very first measurement is delayed by approximately 12 ms.

Due to the thermal measurement principle, a total warm-up time of typically 50 or 60 ms (-1300D or -0600D respectively) is necessary for a reliable measurement. This includes the 12 ms needed for measurement initialization.

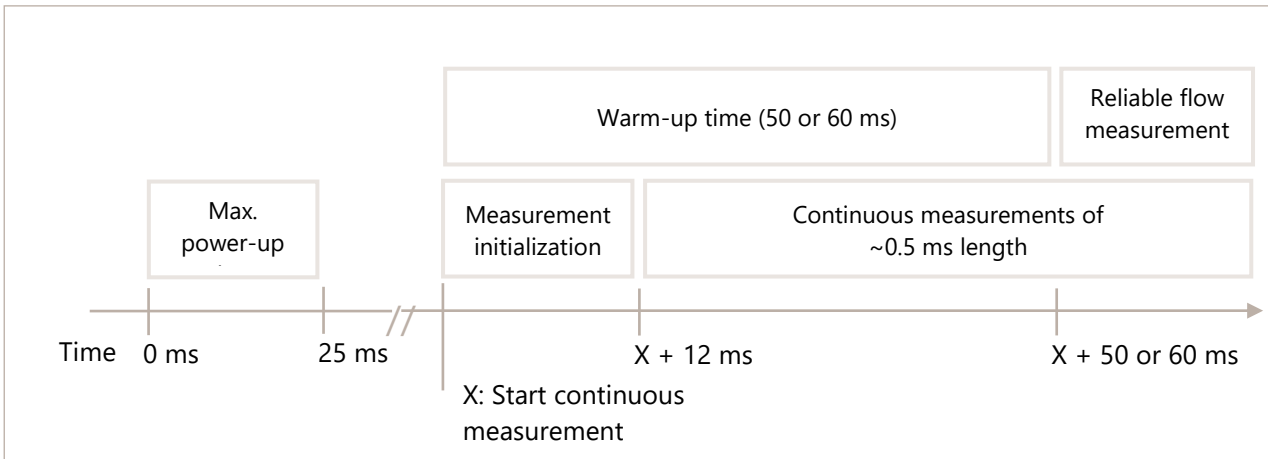

Figure 9. Schematics of SLF3S sensor start-up and warm-up timings.

4.6 New data interrupt – IRQn Functionality

The new data interrupt can be enabled via the procedure described in the application note *Changing the I²C-Address and Activating New Data Interrupt*. When enabled, the function is available on pin 1 (IRQn pin).

The IRQn pin indicates the availability of new measurement data:

- IRQn = 0 → new data available
- IRQn = 1 → no new data available

The signal is automatically cleared (set to high) when a flow measurement value is read.

5 Digital Interface Description

The sensor’s digital interface is compatible with the I²C protocol. This chapter describes the available command set. For detailed information about the I²C protocol, please consult the document "NXP I²C-bus specification and user manual" (http://www.nxp.com/documents/user_manual/UM10204.pdf).

The physical interface consists of two bus lines, a data line (SDA) and a clock line (SCL) which need to be connected via pull-up resistors to the bus voltage of the system.

5.1 I²C Address

The sensor’s I²C address is 8. The I²C header is formed by the I²C address followed by a read or write bit. The I²C-Address can be changed by connecting the IRQn-pin of the sensor to a microcontroller and following the steps explained in the application note "Changing the I2C-Address and activating new data interrupt". Please note that procedure needs to be repeated after every hard or soft reset of the sensor.

5.2 I²C Sequences

The commands are 16-bit. Data is read from the sensor in multiples of 16-bit words, each followed by an 8-bit checksum to ensure communication reliability.

I²C master sends the write header and writes a 16 bit command

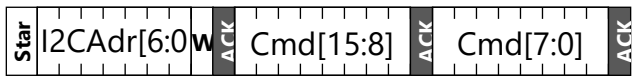

I²C master sends the read header and receives multiple 16bit words with CRC byte.

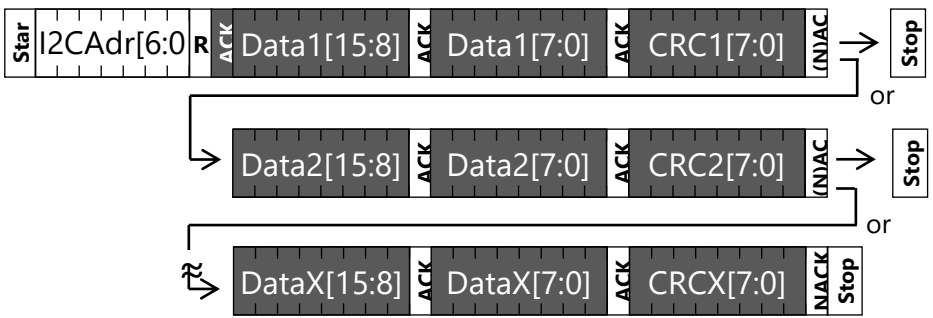

Dark areas with white text indicate that the sensor controls the SDA (Data) line.

I²C sequences can be aborted with a NACK and STOP condition.

5.3 I²C Commands

The command set consists of the following commands:

- Start continuous measurement command
- Stop measurement command
- Soft reset
- Read product identifier and serial number

5.3.1 Start Continuous Measurement

The sensor measures both the flow rate and the temperature. Both measurement results can be read out through one single I²C read header while a continuous measurement is running.

There are two calibrations for H₂O and IPA stored on the sensor. The applicable calibration needs to be chosen by the respective I²C command listed below.

Command	Medium	Command code (Hex)	Description
Start continuous measurement	Water	0x3608	This command starts the continuous measurement mode for H ₂ O. Outputs are the liquid flow rate, the sensor's temperature and the signaling flags.
	Isopropyl alcohol	0x3615	This command starts the continuous measurement mode for IPA. Outputs are the liquid flow rate, the sensor's temperature and the signaling flags.

Table 12. I²C command to start continuous measurement.

After the command has been sent, the chip continuously measures and updates the measurement results as described in section 3.6. New results (flow, temperature, and signaling flags) can be read continuously with a single I²C read header for each set of measurements.

After the start measurement command is sent:

- the first measurement result is available after 12 ms;
- small accuracy deviations (% m.v.) can occur while the sensor warms-up (see section **Error! Reference source not found.**).

While no measurement data is available yet, the sensor will respond with a NACK to the I²C read header (I²C address + read bit).

Preceding command	Consecutive read	Description
Continuous measurement	Byte1: Flow 8msb Byte2: Flow 8lsb Byte3: CRC Byte4: Temp 8msb Byte5: Temp 8lsb Byte6: CRC Byte7: Signaling flags 8msb Byte8: Signaling flags 8lsb Byte9: CRC	After a start continuous measurement command, the measurement results can be read out. The temperature and the consecutive bytes don't need to be read out (every time). The read sequence can be aborted by a NACK and a STOP condition. Bit 0 and bit 1 of the signaling flags are used to detect air-in-line and high flow events. Bit 5 of the signaling flags indicates whether the sensor uses exponential smoothing for flow data averaging. Bit 2 ... 4 and 6 ... 15 are reserved for future use.

Table 13. Consecutive reads after I²C command to start continuous measurement.

Bit	Signaling flag (set to high = 1, set to low = 0)
0	<i>Air-in-Line flag</i> (Limited to large bubbles. See section 3.3.2)
1	<i>High Flow flag</i>
2-4	<i>Unused, reserved for future use.</i>
5	<i>Exponential smoothing active</i>
6-15	<i>Unused, reserved for future use.</i>

Table 14. Bit assignment of 16 bit signaling flags.

5.3.2 Stop Continuous Measurement

Command	Command code (Hex)	Description
Stop continuous measurement	0x3FF9	This command stops the continuous measurement and puts the sensor in idle mode. After it receives the stop command, the sensor needs up to 0.5 ms to power down the heater, enter idle mode and be receptive for a new command.

Table 15. I²C command to stop continuous measurement

When the sensor is in continuous measurement mode, the measurement must be stopped before it can accept another command. The only exception is the soft reset command.

In idle mode the sensor will consume less power.

5.3.3 Soft Reset

Command	I ² C address + W bit + command code (Hex)	Consecutive read	Description
General call reset	0x0006	NA	This sequence resets the sensor with a separate reset block, which is as much as possible detached from the rest of the system on chip. <u>Note that the I²C address is 0x00, which is the general call address, and that the command is 8 bit, i.e., the soft reset command must not be preceded by an I²C write header. The reset is implemented according to the I²C specification.</u>

Table 16. Reset command.

After the reset command, the sensor will take maximum 25 ms to reset. During this time the sensor will not acknowledge its address nor accept commands.

5.3.4 Read Product Identifier and Serial Number

The product identifier and serial number can be read out after sending a sequence of two commands.

First the I²C master sends two consecutive write headers and writes 16 bits for each command. Then the I²C master sends the read header and receives 6 words of 16 bit with a CRC byte after each word.

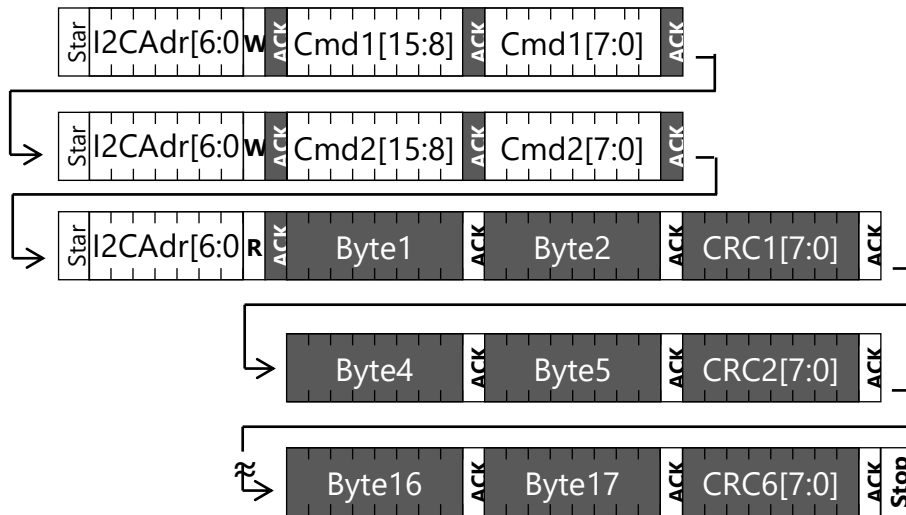

Dark areas with white text indicate that the sensor controls the SDA (Data) line.

Command	Command code (Hex)	Consecutive read	Description
Read product identifier	0x367C 0xE102	Byte1: Product number [31:24] Byte2: Product number [23:16] Byte3: CRC Byte4: Product number [15:8] Byte5: Product number [7:0] Byte6: CRC Byte7: Serial number [63:56] Byte8: Serial number [55:48] Byte9: CRC Byte10: Serial number [47:40] Byte11: Serial number [39:32] Byte12: CRC Byte13: Serial number [31:24] Byte14: Serial number [23:16] Byte15: CRC Byte16: Serial number [15:8] Byte17: Serial number [7:0] Byte18: CRC	Note that both commands need to be preceded with an I ² C write header (I ² C address + W). The second command returns: <ul style="list-style-type: none"> - 32 bit product and revision number. The number is listed in the table below. <i>Note that the last 8 bits are the sensor's revision number and are subject to change in case of an update of the specifications.</i> - 64 bit unique serial number

Table 17. Read product identifier

Product	Product number
SLF3S-0600D	0x07030901
SLF3S-1300D	0x07030801

Table 18. Product number for SLF3S-xxxxD.

5.4 Checksum Calculation

The 8-bit CRC checksum transmitted after each data word is generated by a CRC algorithm. Its properties are displayed in Table 19. The CRC covers the contents of the two previously transmitted data bytes. To calculate the checksum only these two previously transmitted data bytes are used.

Property	Value
Name	CRC-8
Protected data	read data
Width	8 bit
Polynomial	0x31 ($x^8 + x^5 + x^4 + 1$)
Initialization	0xFF
Reflect input	False
Reflect output	False
Final XOR	0x00
Example	CRC (0xBEEF) = 0x92

Table 19. Checksum definition.

5.5 Conversion to Physical Values

Conversion of the liquid flow rate and temperature sensor signals to a physical value is done with the scale factor.

5.5.1 Scale Factors

Parameter	SLF3S-0600D	SLF3S-1300D
Liquid Flow Rate	10 (ul/min) ⁻¹	500 (ml/min) ⁻¹
Temperature	200 °C ⁻¹	200 °C ⁻¹

Table 20. Scale factors.

5.5.2 Liquid Flow Rate

The digital calibrated liquid flow rate signal read from the sensor is a 16 bit signed integer number (two's complement number ranging from -32768 ... 32767). Note that within the sensor's output (e.g. ±65 ml/min for SLF3S-1300D), it will only output values in the range -32500 ... 32500). The integer value can be converted to the physical value by dividing it by the scale factor (liquid flow rate in ml/min = sensor output / scale factor).

5.5.3 Temperature

The digital calibrated temperature signal read from the sensor is a 16 bit signed integer number (two's complement number ranging from -32768 ... 32767). The integer value can be converted to the physical value by dividing it by the scale factor (temperature in °C = sensor output / scale factor).

6 Ordering Information

Use the product names and article numbers shown in the following table when ordering SLF3S-xxxxD liquid flow sensors and the SLF3S-xxxxD evaluation kit. All products are available via Sensirion’s worldwide distribution network. Please find an overview for your region under: www.sensirion.com/distributor-search.

Product	Description	Article Number
SLF3S-0600D liquid flow sensor	2 ml/min, with downmount mounting	3.001.156
SLF3S-1300D liquid flow sensor	40 ml/min, with downmount mounting	3.001.155
Evaluation kit SLF3S-0600D, ready to use	Sensor, USB interface, manifold block (for detailed contents see below)	3.001.236
Evaluation kit SLF3S-1300D, ready to use	Sensor, USB interface, manifold block (for detailed contents see below)	3.001.235

For fast and easy technology evaluation, Sensirion offers a comprehensive SLF3S-xxxxD evaluation kits. Each evaluation kit contains:

- **1 pc SLF3S-0600D** or **SLF3S-1300D** liquid flow sensor
- **1 pc manifold block** to enable mechanical fixation of the sensor and connection by tubes (same for -0600D and -1300D sensors)
- **2 pc o-rings** for the manifold
- **4 M2x10mm screws** to mount the sensor to the manifold
- **Set of barbed connectors** to use the manifold with tubes
- **1 pc SCC1-USB Sensor Cable** with USB connector for plug-and-play connection to a PC
- **1 pc adapter cable** from 6-pin connector to 4-pin M8 which serves as link between sensor and SCC1-USB Sensor Cable, 15 cm length
- **1 pc ribbon cable** from 6-pin connector to pigtail, 30 cm length
- **1 quick start guide** with links to the software
- **PC Software** (Viewer & Data Export Tool) is available for download from Sensirion website

7 Packaging Information

Standard shipment includes only the sensor, neither cables, manifold, nor fluidic connection material. The SLF3S-xxxxD liquid flow sensors are shipped in trays of 50 pcs each. The tray dimension is (350 x 260 x 18) mm³. By piling them up, *Height of the stack* = *No of trays* x 12 mm + 6 mm (e.g. 126 mm for 10 trays).

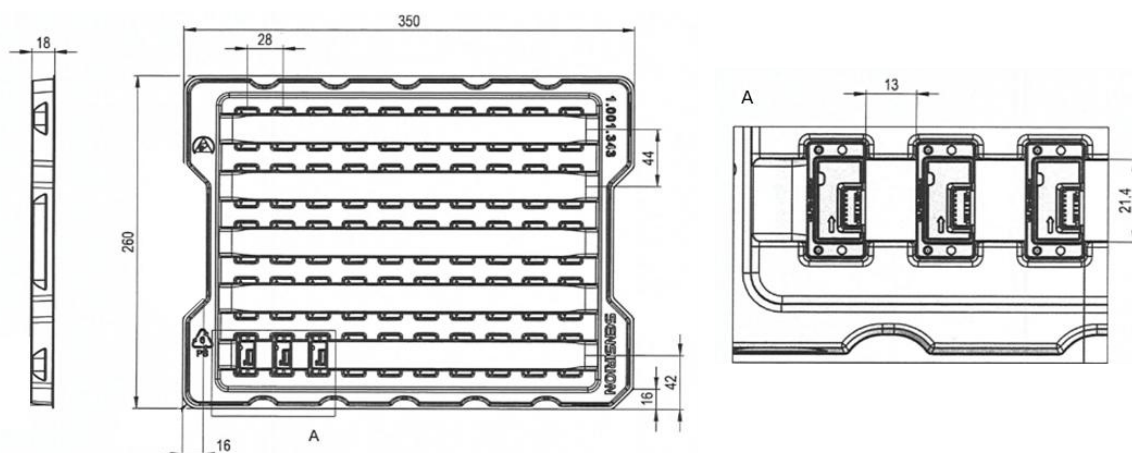

Figure 10. The dimensions of a tray for SLF3S-xxxxD sensors. Each tray holds 50 sensors.

8 Revision History

Date	Version	Pages	Changes
June 2026	1	all	Initial version

Important Notices

Warning, Personal Injury

Do not use this product as safety or emergency stop devices or in any other application where failure of the product could result in personal injury (including death). Do not use this product for applications other than its intended and authorized use. Before installing, handling, using or servicing this product, please consult the data sheet and application notes. Failure to comply with these instructions could result in death or serious injury.

If the Buyer purchases or uses SENSIRION products for any unintended or unauthorized application, Buyer shall defend, indemnify and hold harmless SENSIRION and its officers, employees, subsidiaries, affiliates and distributors against all claims, costs, damages and expenses, and reasonable attorney fees arising out of, directly or indirectly, any claim of personal injury or death associated with such unintended or unauthorized use, even if SENSIRION is allegedly negligent with respect to the design or the manufacture of the product.

ESD Precautions

The inherent design of this component causes it to be sensitive to electrostatic discharge (ESD). To prevent ESD-induced damage and/or degradation, take customary and statutory ESD precautions when handling this product. See application note "ESD, Latchup and EMC" for more information.

Warranty

SENSIRION solely warrants to the original purchaser of this product for a period of 12 months (one year) from the date of delivery that this product is of the quality, material and workmanship defined in SENSIRION's published specifications of the product. Within such period, if proven to be defective, SENSIRION shall as sole and exclusive remedy, in SENSIRION's discretion, repair this product or send a replacement product, free of charge to the Buyer, provided that:

- notice in writing describing the defects shall be given to SENSIRION within fourteen (14) days after their appearance;
- such defects shall be found, to SENSIRION's reasonable satisfaction, to have arisen from SENSIRION's faulty material or workmanship;
- the defective product shall be returned to SENSIRION's factory at the Buyer's expense; and
- the warranty period for any repaired or replaced product shall be limited to the unexpired portion of the original period.

The Buyer shall at its own expense arrange for any dismantling and reassembly that is necessary to repair or replace the defective product. This warranty does not apply to any product which has not been installed or used within the specifications recommended by SENSIRION. EXCEPT FOR THE WARRANTIES EXPRESSLY SET FORTH HEREIN, SENSIRION MAKES NO WARRANTIES, EITHER EXPRESS OR IMPLIED, WITH RESPECT TO THE PRODUCT. ANY AND ALL WARRANTIES, INCLUDING WITHOUT LIMITATION, WARRANTIES OF MERCHANTABILITY OR FITNESS FOR A PARTICULAR PURPOSE, ARE EXPRESSLY EXCLUDED AND DECLINED.

SENSIRION is only liable for defects of this product arising under the conditions of operation provided for in the data sheet and proper use of the goods. SENSIRION explicitly disclaims all warranties, express or implied, if the goods are operated or stored not in accordance with the technical specifications.

SENSIRION does not assume any liability arising out of any application or use of any product or circuit and specifically disclaims any and all liability, including without limitation indirect, consequential, and incidental damages, and loss of profit. No obligation or liability shall arise or grow out of SENSIRION's rendering of technical advice, consulting, or implementation instructions or guidelines. All operating parameters, including without limitation recommended parameters, must be validated for each Buyer's applications by Buyer's technical experts. Recommended parameters can and do vary in different applications.

SENSIRION reserves the right, without further notice, (i) to change the product specifications and/or the information in this document and (ii) to improve reliability, functions and design of this product.

Headquarters and Subsidiaries

Sensirion AG

Laubisruetistr. 50
CH-8712 Staefa ZH
Switzerland
phone: +41 44 306 40 00
fax: +41 44 306 40 30
info@sensirion.com
www.sensirion.com

Sensirion Inc., USA

phone: +1 312 690 5858
info-us@sensirion.com
www.sensirion.com

Sensirion Korea Co. Ltd.

phone: +82 31 337 7700~3
info-kr@sensirion.com
www.sensirion.com/kr

Sensirion Japan Co. Ltd.

phone: +81 45 270 4506
info-jp@sensirion.com
www.sensirion.com/jp

Sensirion China Co. Ltd.

phone: +86 755 8252 1501
info-cn@sensirion.com
www.sensirion.com/cn

Sensirion Taiwan Co. Ltd

phone: +886 2 2218-6779
info@sensirion.com
www.sensirion.com

To find your local representative, please visit
www.sensirion.com/distributors