

Datasheet SFC5300 / SFM5300 mass flow controller / meter for gases
Product Information October 2016 – V1

- Ultra-fast settling time (down to 50 ms)
- Excellent accuracy / repeatability (2% s.p. / 0.2% s.p. respectively)
- Wide control range (1000:1)
- Two digital interfaces: RS485, IO-Link
- Compact downmount footprint
- Multiple gases and gas recognition
- NIST traceable calibration



SFC5300

Unsurpassed CMOSens® Technology

The SFC5300 / SFM5300 series continues Sensirion's pioneering work in MEMS-based mass flow controllers and meters: The heart of this product is the unsurpassed Sensirion CMOSens® technology. It combines a high precision sensor element with state of the art signal processing on a single chip and thereby providing an accurately calibrated and temperature compensated signal (see Figure 1). Thanks to this sensor technology, the SFC5300 achieves unmatched ratings for speed, accuracy and repeatability. In addition, no recalibration is needed due to the inherent longterm stability of the CMOSens® technology.

The SFC5300 offers fastest settling time, high control range as well as high flexibility regarding mechanical connectors and communication interfaces. Digital versions also provide optional smart features like multiple gases and ranges, gas recognition and self-test capability.

The SFM5300 is the valve-free flow meter based on the SFC5300 mass flow controller. It features the same

performance advantages and configurations as the MFC counterpart without providing the controller functionality.

The brilliant performance of the SFC5300 / SFM5300 products makes them the best choice for a wide range of applications, such as analytical instrumentation, medical equipment and general process automation to name a few.

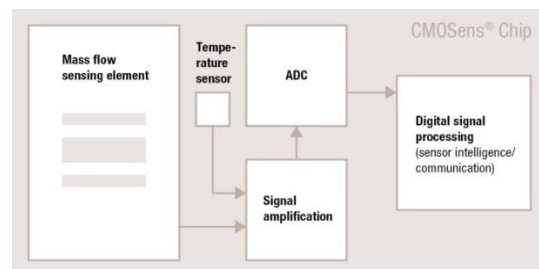

Figure 1: CMOSens® flow sensor diagram.

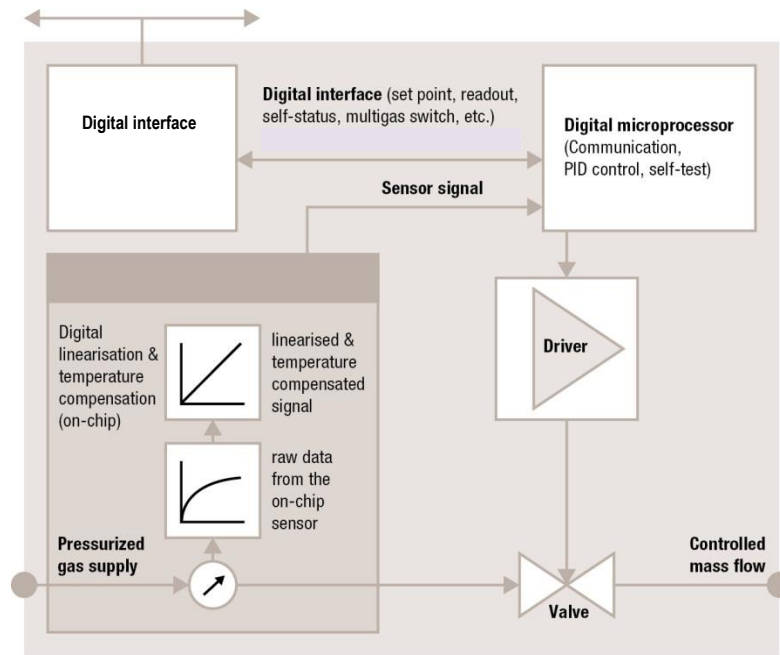

Figure 2: Block Diagram CMOSens[®] SFC5300 mass flow controller.

Introductory Description

The CMOSens[®] based SFC5300 / SFM5300 measure the gas mass flow by the calorimetric principle based on heat transfer. A heating element on a thermally insulated membrane is kept above ambient temperature. In the presence of gas flow, the temperature distribution up- and downstream is disturbed. This asymmetry is then measured. The whole arrangement is realized on a silicon chip using CMOS standard processes (see Figure 3).

MEMS based CMOSens[®] technology enables a larger cross section (about 1.5x1 mm²) of the gas channel than bypass capillary diameter in conventional mass flow controllers (0.1 to 0.5 mm). This channel design makes the device more robust against particles, clogging and humidified gases. Due to the compact single-chip design and its mounting between metal parts, CMOSens[®] based sensors are very resistant to electromagnetic disturbances (EMC).

The minimal thermal mass of the membrane results in an ultra-fast sensor response time of 3-4 ms. Since the whole design of the amplification, A/D conversion, digital linearization and temperature compensation is matched to that sensor speed, a fully compensated flow measurement value can be delivered every millisecond. Combined with advanced control algorithms running on

an on-board microprocessor, the SFC5300 offers greatly reduced settling times compared to conventional mass flow controllers (see Figure 2).

Furthermore, a special arrangement of the two temperature sensors, the on-chip temperature compensation and the minimizing of noise sources lead to the unbeatable performance with regard to repeatability and accuracy over a large dynamic range. Thanks to its flawless design, the SFC5300 / SFM5300 mass flow controllers / meters show zero-drift performance and control / measure true mass flow independently of the ambient temperature and pressure changes.

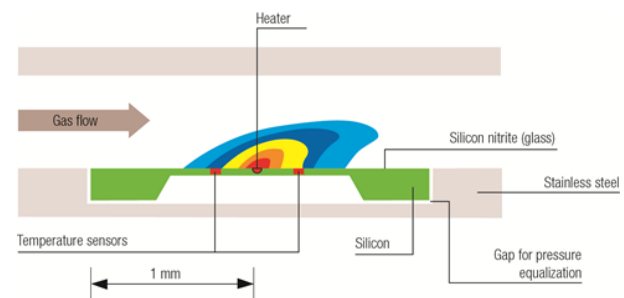

Figure 3: Cross-sectional view of gas channel.

1 CMOSens® SFC5300 / SFM5300 mass flow controller / meter performance

Table 1: Overview of CMOSens® SFC5300 / SFM5300 Mass Flow Controller / Meter Specifications

All data, unless otherwise noted, apply for the following calibration conditions: Temperature 20°C, Nitrogen (N₂), 3.0 bar overpressure (inlet: 4.0 bar absolute) against atmosphere (outlet: 1.0 bar absolute), horizontal mounting position (electric connector on top), downmount connection

Specification	Value	Unit
Full scale flow (N ₂ equivalent)	0.05, 0.1, 0.2, 0.5, 1, 2, 5, 10	l _n /min or slm
Accuracy ¹ whichever is greater	2 0.2	% s.p. ² % FS
Repeatability whichever is greater	0.1 0.01	% s.p. % FS
Typical settling time ³	100 (50 on request)	ms
Measurement frequency	1000	Hz
Control range ⁴	Better than 1000:1	
Standard calibration gases	Air/N ₂ , H ₂ , O ₂ , He, Ar, CO ₂	
Calibrations using gas conversion ⁵ (on request)	SF ₆ , C ₄ F ₈ , CF ₄ , NH ₃ , SiH ₄ , N ₂ O, O ₃ , CO, CH ₄ , CH ₃ F, Xe, Ne, Kr + other gases and mixtures on request (not compatible with aggressive gases, see wetted material list or contact Sensirion)	
Operating temperature (ambient and gas)	0 – 50 / 32 – 122	°C / °F
Temp. coeff. zero	0.005	% FS / °C
Temp. coeff. span	0.06	% s.p. / °C
Pressure drop at full flow SFC5300 SFM5300	< 2.0 / 29 < 0.1 / 1.5	bar / psig
Maximum input pressure ⁶	10 / 145	bar / psig
Maximum differential pressure ⁷	5 / 73	bar / psig
Leak integrity MFC external	9 x 10 ⁻⁹	mbar l/s He
Warming up time ⁸	1	sec
Weight short / long version	140 / 171	g

¹ Including offset, non-linearity and hysteresis. Measured against NIST traceable reference

² in % of set point (s.p.) = measured value (m.v.) = rate = reading

³ Step answer from 10% to 100% of full scale within ±5% of set point

⁴ Specification is valid for mass flow controller only

⁵ Gas conversion is generated from the real gas calibration data using the combination of standard gases. Typical accuracy is 2% m.v. / 0.2% FS (whichever is greater). Please contact Sensirion if better accuracy specification is required

⁶ Pressure between flow inlet and ambient

⁷ Pressure between flow inlet and flow outlet. For availability of higher differential pressure option, contact Sensirion

⁸ to within ±2 % of set point

1.1 Accuracy

Figure 4 compares the set point accuracy of a conventional mass flow controller / meter with a CMOSens® SFC5300 / SFM5300. Typically, an accuracy of 1% FS (full scale) is stated for mass flow controllers using conventional sensor technology. The graph shows this in relation to the accuracy of the SFC5300 mass flow controller. It can be seen that especially at low flow rates the CMOSens® technology reaches superior performance.

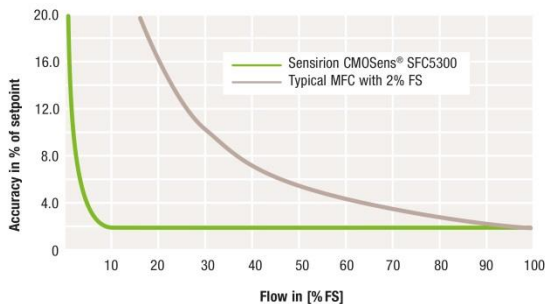

Figure 4: Accuracy comparison of the CMOSens® SFC5300 / SFM5300 device compared to a typical thermal mass flow controller / meter.

1.2 Repeatability

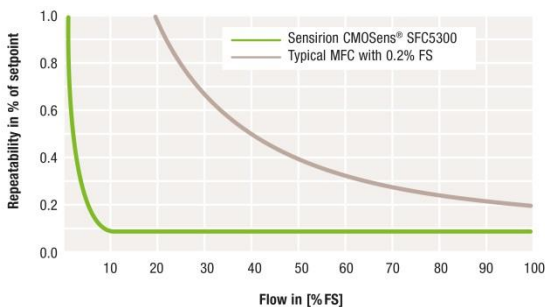

Figure 5: Repeatability comparison of the CMOSens® SFC5300 / SFM5300 device compared to a typical thermal mass flow controller/meter.

1.3 Settling time

The CMOSens® SFC5300 mass flow controller has an ultra-fast settling time. Figure 6 shows the typical response time of the SFC5300 in comparison to a mass flow controller using conventional sensor technology.

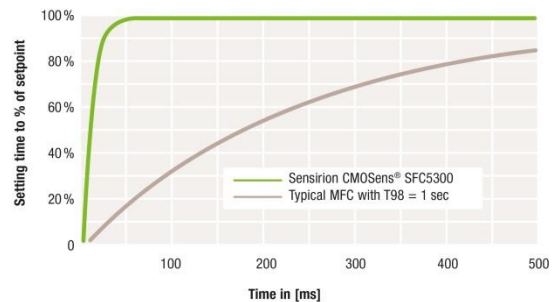

Figure 6: Settling time of the SFC5300 vs. typical thermal mass flow controller.

1.4 Wide control range

Ultra-wide control range of the SFC5300 brings a decisive benefit in applications with a wide dynamic range of gas flows. Instead of two devices used for high flow and low flow ranges, a single SFC5300 device can efficiently cover a flow range of three orders of magnitude.

1.5 Multiple gases, ranges & gas recognition

The new SFC5300 / SFM5300 can be equipped with multigas feature allowing switching between a set of gas calibrations saved in the device memory. Similarly, different ranges for the same gas can be stored. Another interesting feature is gas recognition. It allows performing a check whether the activated gas calibration matches the media in the gas line. This is a safety feature which prevents wrong operation due to mistake of user etc.

2 Construction details

2.1 Packaging principle and sealing

To guarantee a vacuum proof housing of the sensor and the flow path, several patented technologies are used. The CMOSens® chip itself is placed vacuum tight in a stainless steel package that is connected via O-ring sealing to the aluminium body. The packaging allows the SFC5300 / SFM5300 mass flow controller / meter to operate under high input pressure conditions (up to 10 bar / 145 psi standard).

The electrical connection from the chip to the main controller board is realized using vacuum tight glass feed through pins. This chosen packaging method ensures high reliability and tightness for all kinds of gases (see Figure 7 below).

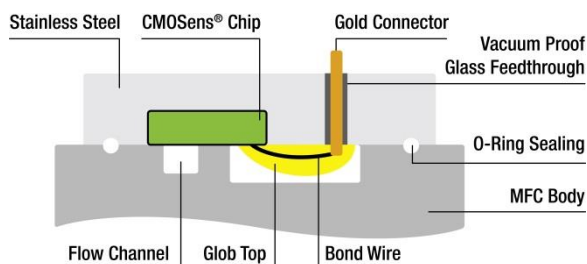

Figure 7: Vacuum tight glass feed through (longitudinal view)

2.2 Wetted materials & compatibility

The packaging method ensures that a minimum number of inert materials are wetted by the media. Table 2 gives an overview of the materials wetted by the gas. For high volume applications different specialized materials for body, valve and sealing can be used.

Table 2: Overview of Wetted Materials. Standard configuration materials are shown in bold text. Optional materials are provided for large projects only.

Part	Wetted Material
Body	Aluminum Stainless steel or plastic on request
Sensor element	Silicon (Si) Silicon oxide (SiO_x) Silicon nitride (Si₃N₄) Stainless steel Glass Glob top
Sealing	FKM EPDM / FFKM on request
Valve	Brass, FKM Stainless steel, EPDM / FFKM on request

2.3 Safety instructions

2.3.1 Toxic gases

The whole gas assembly must be checked for leakage before applying toxic gas to the device.

2.3.2 Aggressive or corrosive gases

Please make sure that the gases you use are compatible with the wetted materials listed in this chapter. In case of doubt please contact Sensirion for further advice.

2.3.3 Explosive gases

The maximum heating energy of the sensor is limited to 12 mW in every circumstance, even in the case of a failure. The CMOSens® sensor element is tested according to EN 50020 chapter 6.2.4 b). Sensirion guarantees the safe use of gases of the classes T1 or T2 (ignition temperature < 300 °C). This includes also mixtures of air or oxygen with hydrogen or hydrocarbons. However, the SFC5300 / SFM5300 are not designed for the use in hazardous areas (EN 60079-10) where explosive gases can occur outside of the device.

3 Electrical and communication specifications

3.1 Connector and pin layout

SFC5300 / SFM5300 feature two digital interfaces: RS485, IO-Link. Detailed specification of the digital communication protocols can be found on the Sensirion website.

The electrical connector of the SFC5300 / SFM5300 is a standard Sub-D 9pin. This enables an easy and reliable universal connection. See the pin layouts for different interface versions below:

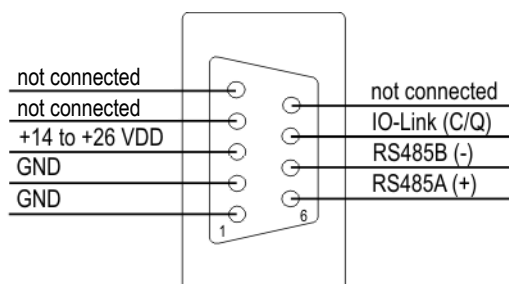

Figure 8: Digital interface (RS485 and IO-Link)

3.2 Power supply

The SFC5300 / SFM5300 mass flow controller / meter require a standard voltage supply of +14.0 to + 26.0 VDC. There are no stringent requirements for voltage ripple and stability because of the internal voltage regulation.

3.3 Electrical specifications

Table 3: Electrical characteristics

Parameter	Conditions	Units
Analog and digital versions		
Supply Voltage Range (VDD)	Typ 15.0 – 24.0 Max 14.0 –26.4	VDC
Electrical Connector	D-Sub 9pin (female on device)	

Table 4: Current consumption

Parameter	Conditions	Typical value (within +/- 5%)	Units
Flow range equal and below 500 sccm N2 equivalent			
Max. Supply Current	VDD = 15 / 24 VDC	120 / 75	mA
Standby current	VDD = 15 / 24 VDC	50 / 35	mA
Flow range higher than 500 sccm N2 equivalent			
Max. Supply Current	VDD = 15 / 24 VDC	320 / 200	mA
Standby current	VDD = 15 / 24 VDC	50 / 35	mA
Mass flow meter SFM5300			
Typical	VDD = 15 / 24 VDC	50 / 35	mA

Table 5: Electromagnetic compatibility

Parameter	Hall mark	Notes	Applied values
Electromagnetic Compatibility / Immunity in Industrial Environment: (EN 61000-6-2)	EN 61000-4-2	Air discharge (ESD)	± 8 kV (air) ± 4 kV (contact)
	EN 61000-4-6	High frequency electromagnetic radiation (HF)	10 V _{eff}
	EN 61000-4-4	Fast transients (burst)	± 4 kV

4 Physical dimensions and mounting information for SFC5300 / SFM5300

SFC5300 / SFM5300 come in two downmount variants: A shorter variant (top panel) with two downward facing screw threads and a longer variant (bottom panel) with four screw holes.

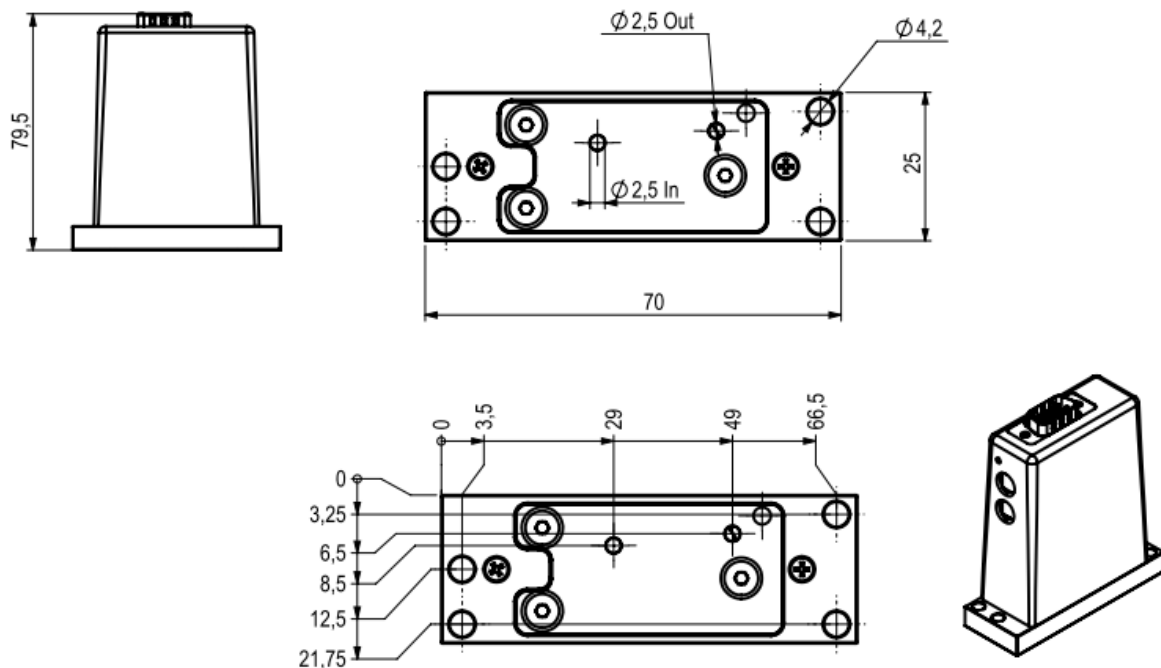
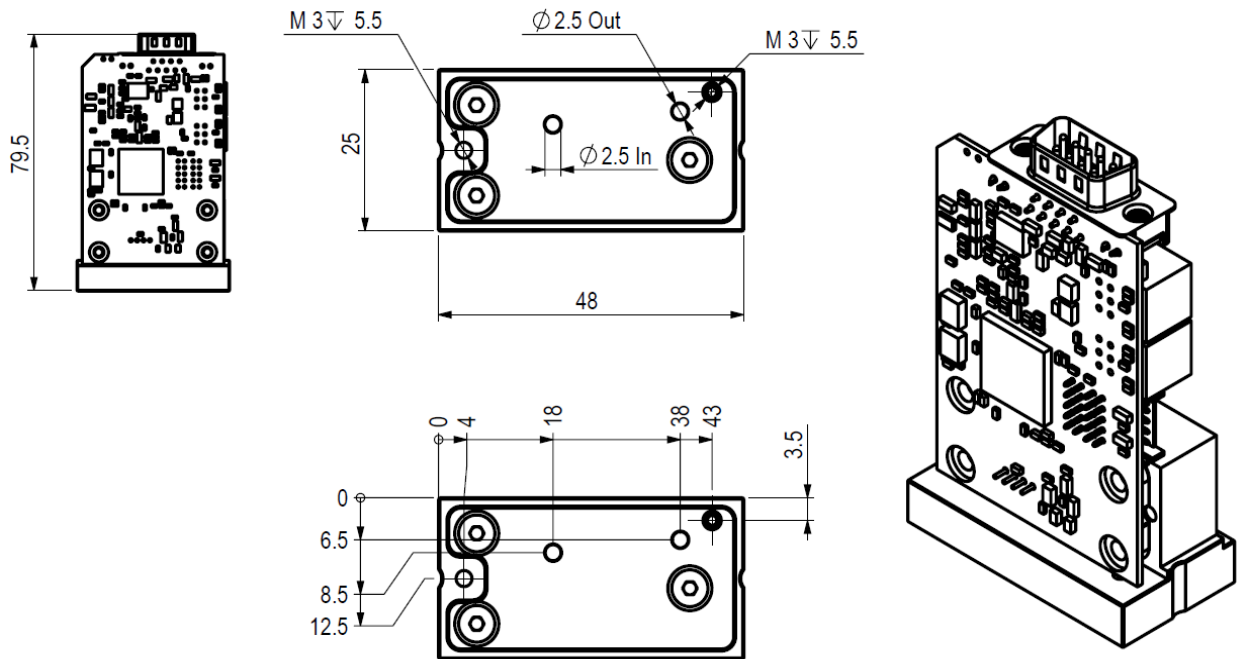

5 Supported flow units

Table 6: Units for gas flow rates

Typical flow unit	Reference condition	
	Gas Temperature	Gas Pressure
mln/min (norm milliliter per minute)	0 °C / 32° F	1013 mbar / 14.69 psi
ln/min (norm liter per minute)		
sccm (standard cubic centimeter per minute)	20 °C / 68° F	
slm (standard liter per minute)		

Example: Relationship for N₂ between:

ln/min (0°C, 1013 mbar)	and	slm (20°C / 68°F, 1013 mbar / 14.69)
1 ln/min	=	1.073 slm
10 ln/min	=	10.73 slm

6 Revision history

Date	Version	Page(s)	Changes
September 2016	V1	All	

Important notices

Warning, personal injury

Do not use this product as safety or emergency stop device or in any other application where failure of the product could result in personal injury. Do not use this product for applications other than its intended and authorized use. Before installing, handling, using or servicing this product, please consult the data sheet and application notes. Failure to comply with these instructions could result in death or serious injury.

If the Buyer shall purchase or use SENSIRION products for any unintended or unauthorized application, Buyer shall defend, indemnify and hold harmless SENSIRION and its officers, employees, subsidiaries, affiliates and distributors against all claims, costs, damages and expenses, and reasonable attorney fees arising out of, directly or indirectly, any claim of personal injury or death associated with such unintended or unauthorized use, even if SENSIRION shall be allegedly negligent with respect to the design or the manufacture of the product.

ESD precautions

The inherent design of this component causes it to be sensitive to electrostatic discharge (ESD). To prevent ESD-induced damage and/or degradation, take customary and statutory ESD precautions when handling this product.

Warranty

SENSIRION warrants solely to the original purchaser of this product for a period of 12 months (one year) from the date of delivery that this product shall be of the quality, material and workmanship defined in SENSIRION's published specifications of the product. Within such period, if proven to be defective, SENSIRION shall repair and/or replace this product, in SENSIRION's discretion, free of charge to the Buyer, provided that:

- notice in writing describing the defects shall be given to SENSIRION within fourteen (14) days after their appearance;

- such defects shall be found, to SENSIRION's reasonable satisfaction, to have arisen from SENSIRION's faulty design, material, or workmanship;
- the defective product shall be returned to SENSIRION's factory at the Buyer's expense; and
- the warranty period for any repaired or replaced product shall be limited to the unexpired portion of the original period.

This warranty does not apply to any equipment which has not been installed and used within the specifications recommended by SENSIRION for the intended and proper use of the equipment. EXCEPT FOR THE WARRANTIES EXPRESSLY SET FORTH HEREIN, SENSIRION MAKES NO WARRANTIES, EITHER EXPRESS OR IMPLIED, WITH RESPECT TO THE PRODUCT. ANY AND ALL WARRANTIES, INCLUDING WITHOUT LIMITATION, WARRANTIES OF MERCHANTABILITY OR FITNESS FOR A PARTICULAR PURPOSE, ARE EXPRESSLY EXCLUDED AND DECLINED.

SENSIRION is only liable for defects of this product arising under the conditions of operation provided for in the data sheet and proper use of the goods. SENSIRION explicitly disclaims all warranties, express or implied, for any period during which the goods are operated or stored not in accordance with the technical specifications.

SENSIRION does not assume any liability arising out of any application or use of any product or circuit and specifically disclaims any and all liability, including without limitation consequential or incidental damages. All operating parameters, including without limitation recommended parameters, must be validated for each customer's applications by customer's technical experts. Recommended parameters can and do vary in different applications.

SENSIRION reserves the right, without further notice, (i) to change the product specifications and/or the information in this document and (ii) to improve reliability, functions and design of this product.

Copyright© 2001-2016, SENSIRION.

CMOSens® is a trademark of Sensirion

All rights reserved

FCC and CE statement

The SFC5300 and SFM5300 products have been tested and found to comply with the limits for a Class B digital device, pursuant to part 15 of the FCC Rules (FCC CFR 47). These limits are designed to provide reasonable protection against harmful interference in a residential installation. This equipment generates, uses and can radiate radio frequency energy and, if not installed and used in accordance with the instructions, may cause harmful interference to radio communications. However, there is no guarantee that interference will not occur in a particular installation. If this equipment does cause harmful interference to radio or television reception, which can be determined by turning the equipment off and on, the user is encouraged to try to correct the interference by one or more of the following measures:

- Reorient or relocate the receiving antenna.
- Increase the separation between the equipment and the receiver
- Connect the equipment into an outlet on a circuit different from that to which the receiver is connected.
- Consult a dealer or an experienced radio/TV technician for help.



The CMOSens® SFC5300 / SFM5300 devices fully comply with norm EN 61000-6-1 to EN 61000-6-4 (Immunity and Emission Test Series).



Headquarters and subsidiaries

SENSIRION AG
Laubisruetistr. 50
CH-8712 Staefa ZH
Switzerland

phone: +41 44 306 40 00
fax: +41 44 306 40 30
info@sensirion.com
www.sensirion.com

Sensirion AG (Germany)
phone: +41 44 927 11 66
info@sensirion.com
www.sensirion.com

Sensirion Inc., USA
phone: +1 805 409 4900
info_us@sensirion.com
www.sensirion.com

Sensirion Japan Co. Ltd.
phone: +81 3 3444 4940
info@sensirion.co.jp
www.sensirion.co.jp

Sensirion Korea Co. Ltd.
phone: +82 31 345 0031 3
info@sensirion.co.kr
www.sensirion.co.kr

Sensirion China Co. Ltd.
phone: +86 755 8252 1501
info@sensirion.com.cn
www.sensirion.co.cn

To find your local representative, please visit www.sensirion.com/contact