

SFA40 Datasheet

Miniature Electrochemical Formaldehyde Sensor

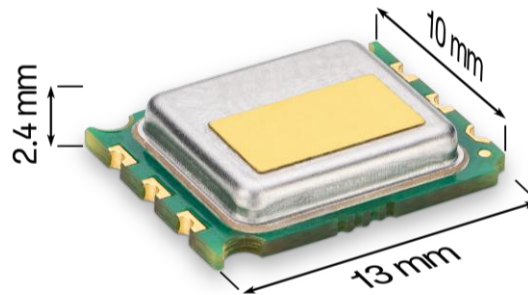

Highlights

- Highly selective to formaldehyde
- Cross-sensitivity to ethanol: 0.3%
- Current consumption: 80 μ A
- Accuracy: ± 20 ppb or $\pm 20\%$
- Calibrated digital output
- Long lifetime: >6 years

The SFA40 is a formaldehyde (HCHO) sensor with outstanding accuracy in the field due to exceptionally low cross-sensitivity to common indoor gases, such as ethanol or nitrogen dioxide. Developed for air purifiers, air conditioners, and indoor air quality monitors, the SFA40 features miniature size, low power consumption and reliable output even in a background of other volatile organic compounds. The sensor is suitable for detecting low formaldehyde concentrations below the limits established by WHO, WELL Building Standard™ and Chinese National Standard GB/T 18883-2022.

This electrochemical sensor has an exceptionally long lifetime due to its advanced anti-dry technology. Each SFA40 is factory-calibrated and can be easily integrated via manual or automated soldering into the final device. This makes the SFA40 a reliable, easy-to-use and high-quality formaldehyde sensing solution, which enables compact devices with long battery life and top performance.

Contents

1	SFA40 Performance Specifications	3
1.1	Formaldehyde.....	3
1.2	Relative Humidity and Temperature.....	3
2	Sensor Specifications	4
2.1	Environmental Conditions	4
2.2	Electrical Specifications.....	4
2.3	Electrical integration	5
2.4	Timing Specifications.....	5
2.5	Absolute Maximum Ratings.....	5
2.6	Pad Assignment and Laser Marking	6
3	Sensor Operation.....	7
3.1	SFA40 functional block diagram	7
3.2	I2C Address.....	7
3.3	Example of I2C Transfer.....	7
3.4	CRC Checksum Calculation	8
3.5	Command Overview.....	9
3.5.1	Start Continuous Measurement.....	9
3.5.2	Read Measurement.....	9
3.5.3	Stop Continuous Measurement.....	10
3.5.4	Read Serial Number.....	10
3.5.5	Start Self-test.....	11
3.5.6	Read Self-test Data	11
3.5.7	Perform Soft Reset	11
3.6	Conversion and Interpretation of the Signal Output.....	12
3.6.1	Pseudocode	12
4	Physical Specifications	14
4.1	Package Description.....	14
4.2	Package Outline.....	14
4.3	Land Pattern.....	14
4.4	Soldering and Desoldering Instructions	14
5	Tape and Reel Packaging	16
5.1	Material Specifications.....	16
6	Ordering Information.....	17
7	Revision History.....	18

1 SFA40 Performance Specifications

Every SFA40 is individually tested and calibrated and is identifiable via a unique serial number (see **Section 3.5.4** for details on the serial number).

1.1 Formaldehyde

Standard conditions of 25 °C, 50 %RH, 101 kPa and 3.3 V supply voltage apply to values in the table below, unless otherwise stated. Clean air is defined as consisting of 78% N₂, 21% O₂, 0.93% Ar, plus variable amounts of CO₂ and H₂O depending on the relative humidity.

Parameter	Comment	Min	Typ	Max	Unit
Formaldehyde measurement range	Range in which sensor gives an output		0 to 2000		ppb
Accuracy	0 to 200 ppb formaldehyde in otherwise clean air	-	±20 ppb or ±20% of measured value, whichever is larger	-	ppb or %
Cross-sensitivity to ethanol	Tested at 5 ppm ethanol in otherwise clean air	-	0.3% (15 ppb output in 5 ppm ethanol)	-	%
Startup time after power on	Time until the sensor output is within specifications	-	10	-	min
Response time	Response to concentration change	-	<2	-	min
Lifetime	At standard conditions	-	>6	-	years
Long-term drift	At standard conditions	-	<5 ppb or <5% of the measured value, whichever is larger	-	per year

Table 1. General SFA40 formaldehyde sensor specifications

1.2 Relative Humidity and Temperature

The relative humidity and temperature (RHT) sensor measures local temperature on the SFA40 board for accurate compensation of RHT effects on the formaldehyde signal. The output of the RHT sensor is affected by the nearby heat sinks and heat sources, and may differ from the ambient RHT conditions.

Parameter	Min	Typ	Max	Unit
Humidity measurement range		0 to 100		%RH
Temperature measurement range		-40 to 125		°C

Table 2. General SFA40 relative humidity and temperature sensor specifications. Please note that the humidity and temperature measurement ranges are wider than the operating humidity and temperature ranges of the SFA40. The sensor shall not be operated outside the specified operating environmental conditions (see **Section 2.1**).

2 Sensor Specifications

2.1 Environmental Conditions

Parameter		Conditions	Min	Max	Unit
Operating conditions	Relative humidity	Non-condensing	10	90	%RH
	Temperature	-	0	50	°C
Recommended storage conditions ¹	Relative humidity	Non-condensing	30	70	%RH
	Temperature	-	10	30	°C

Table 3. Environmental conditions for SFA40.

2.2 Electrical Specifications

Typical values correspond to VDD = 3.3 V and T = 25 °C. Min. and max. values are valid in the full operating temperature range of 0 °C to 50 °C, at declared VDD levels and are based on characterization.

Parameter	Symbol	Conditions	Min	Typ	Max	Unit	Comments
Supply voltage	V _{DD}	-	1.62	3.3	3.6	V	-
Supply voltage peak to peak ripple	V _{DD,pp}	0.1 Hz to 0.5 MHz	-	-	50	mV	
		>0.5 MHz	-	-	20	mV	
Supply current	I _{DD}	Idle state	-	60	90	µA	-
		Measurement: peak	-	0.7	2	mA	Current while sensor is measuring: 21 ms every 500 ms.
		Measurement: average	-	80	-	µA	For 2 Hz continuous operation
Low level input voltage	V _{IL}	-	0	-	0.3*V _{DD}	V	-
High level input voltage	V _{IH}	-	0.7*V _{DD}	-	V _{DD}	V	-
Low level output voltage	V _{OL}	V _{DD} = 1.62 V to 2.0 V	-	-	0.2*V _{DD}	V	-
		V _{DD} > 2.0 V	-	-	0.4	V	
I2C bus capacitive load	C _b	Fast mode	-	-	400	pF	For application circuit refer to Figure 1.

Table 4. Electrical specifications.

¹ In order to optimize for the best performance and lifetime, sensors should be stored in controlled environmental conditions before use.

2.3 Electrical integration

The SFA40, serving as an I2C target, has to be integrated into a circuit with an I2C controller. A typical application circuit is shown in **Figure 1**.

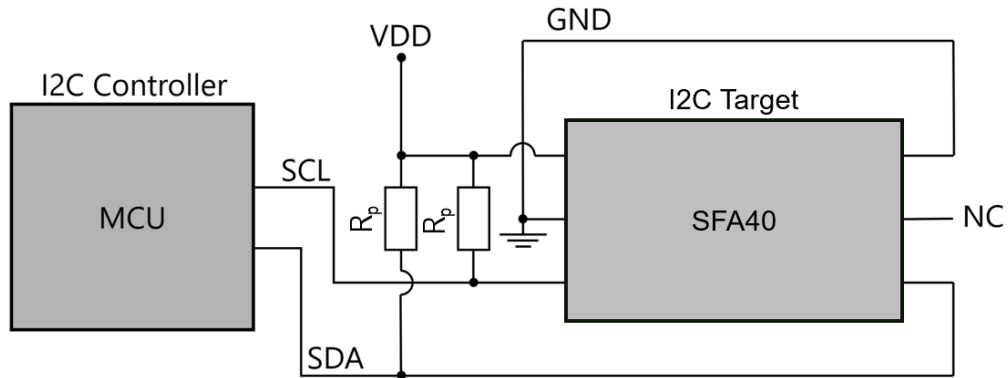

Figure 1. Typical application circuit.

The resistances of the pull-up resistors, R_p , have to be $>390 \Omega$ and selected according to the *NXP's I2C specification and user manual, Ed.7.* and adapted to the external conditions, such as I2C clock frequency and capacitive load of the bus. Capacitive bus load can be determined from $C_b < t_{rise}/(0.8473 \cdot R_p)$. Rise time for fast mode is $t_{rise} = 300 \text{ ns}$.

2.4 Timing Specifications

Parameter	Symbol	Conditions	Min	Typ	Max	Unit	Comments
Internal measurement update interval	-	Continuous measurement mode or self-test mode	-	0.5	0.7	s	Shorter readout intervals by the user will occasionally result in reading the same data point multiple times.
I2C clock frequency	f_{I2C}	-	-	-	400	kHz	The application circuit has to be designed for the desired I2C clock frequency.

Table 5. System timing specifications.

2.5 Absolute Maximum Ratings

Stress levels beyond those listed in the **Table 6** may cause permanent damage to the device. These are stress ratings only and functional operation of the device at these conditions cannot be guaranteed. Exposure to the absolute maximum rating conditions for extended periods may affect the reliability of the device. Ratings are only tested one at a time.

Parameter	Conditions	Min	Max	Unit
Short-term storage conditions (e.g. during transportation)	Relative humidity Non-condensing	5	95	%RH
	Temperature	-40	70	°C
Supply voltage <i>VDD</i>	-	-0.3	+4.0	V
Min./ Max. voltage on I2C pins	-	VSS -0.3	VDD +0.3	V
Latch up, JEDEC Class II	125 °C	-100	+100	mA
ESD HBM	-	-	2	kV

Table 6. Absolute maximum ratings.

2.6 Pad Assignment and Laser Marking

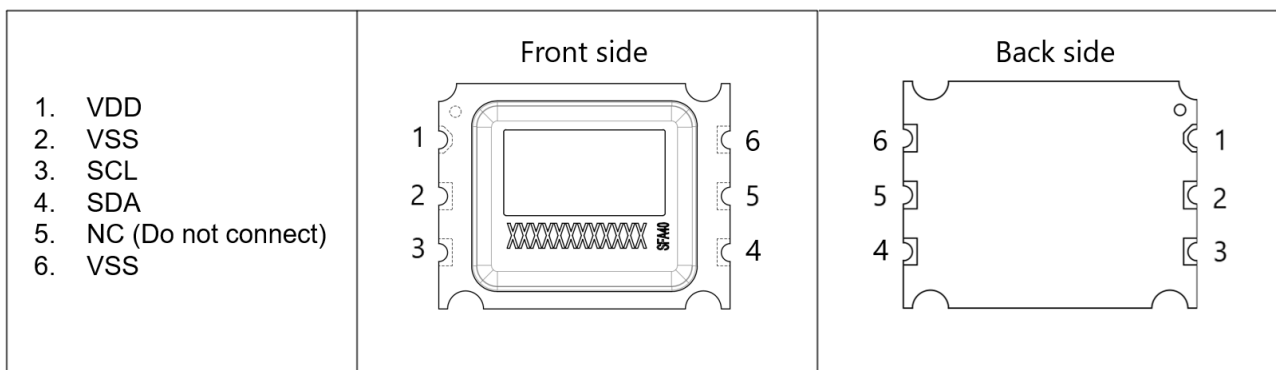

Figure 2. Castellated pad assignment of the SFA40 sensor. Dots on both sides of the PCB and a rounded corner serve as identification marks for the location of castellated pad 1.

The laser marking on the metal cap consists of a 12-digit unique serial number (marked with “XXXXXXXXXXXX” in the figure above) and “SFA40”. The laser-marked serial number corresponds to the serial number that can be read via I2C interface in hexadecimal format (see **Section 3.5.4**).

3 Sensor Operation

The SFA40 uses I2C communication based on *NXP's I2C specification and user manual, Ed.7*. Supported I2C modes are standard (100 kHz) and fast mode (400 kHz). Please follow mandatory capacitor requirements given in **Table 4** and resistor requirements stated in **Section 2.3**.

3.1 SFA40 functional block diagram

A functional block diagram of the device is shown in **Figure 3**. The sensor has a data-processing unit integrated, which autonomously measures the electrochemical signal, compensates it for varying ambient temperature and humidity conditions and converts the signals into a digital formaldehyde concentration output in ppb, using data from the factory-calibration. The communication is done via the I2C protocol.

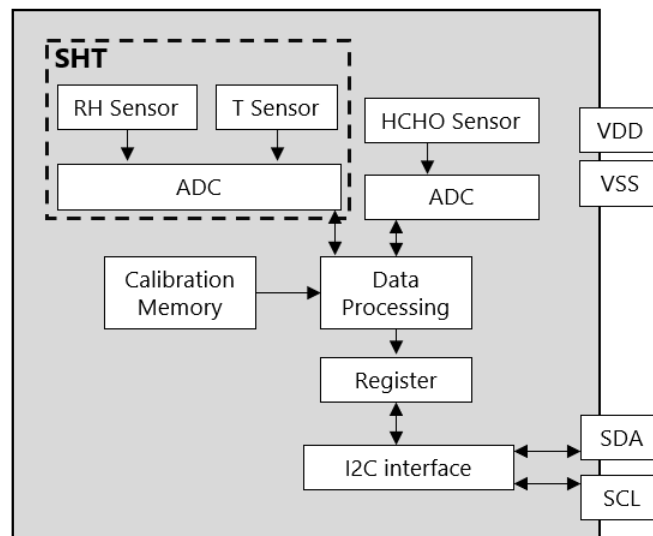

Figure 3. SFA40 functional block diagram.

3.2 I2C Address

The sensors I2C address is listed in the **Table 7**.

Product	I2C Address
SFA40	0x5D (hexadecimal) 93 (decimal)

Table 7. Supported I2C address.

3.3 Example of I2C Transfer

The write, read and combined data transfer formats are visualized in **Figure 4**. Data and commands are transferred in multiples of 16-bit words, with the most significant byte (MSB) transmitted first. All transfers must begin with a start condition (S) and terminate with a stop condition (P). A sensor is addressed by sending its 7-bit I2C address, followed by an eighth bit denoting the communication direction (W/R): “zero” indicates transmission to the target (i.e., “WRITE”) and “one” indicates a request for data (i.e., “READ”). In general, command words are 2 bytes long. Note that the 2nd byte is the CRC of the 1st byte, thereby preventing the accidental executing of an incorrect command. An exception is the *perform_soft_reset* command, which is only 1 byte long and is sent to the I2C general call address (0x00). In read direction, the controller may abort transmission after any data byte by sending a not acknowledge (NACK) and a stop condition.

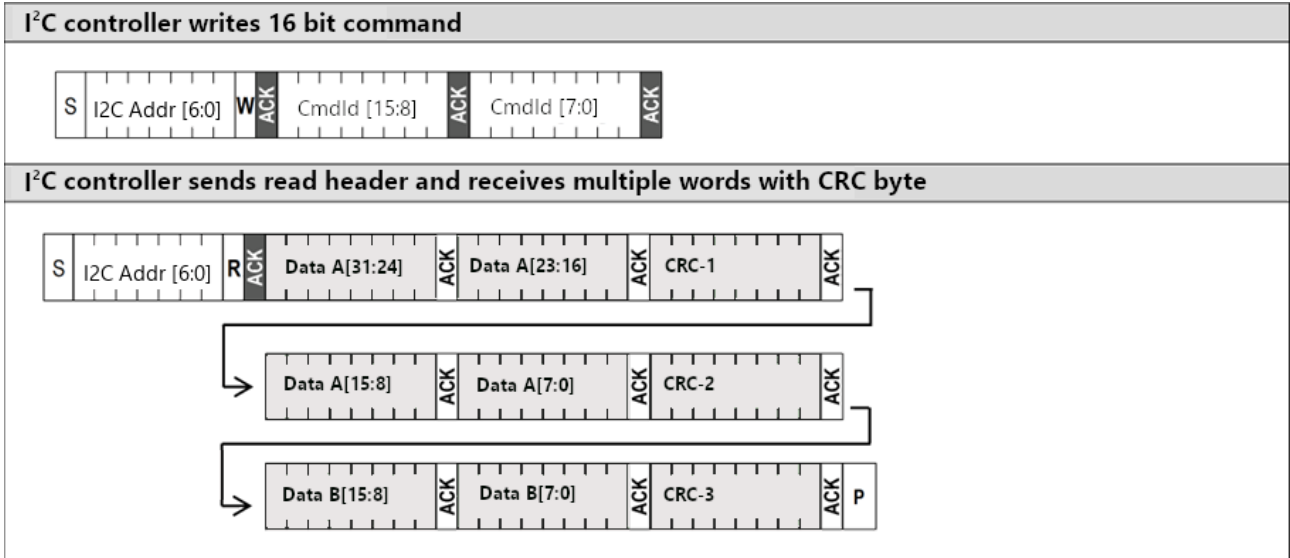

Figure 4. Example of I2C transfer.

As a result of this I2C transfer the variable A and B should contain the following data:

```
A := Data A [31:24],Data A [23:16],Data A [15:8],Data A [7:0]
B := Data B [15:8],Data B [7:0]
```

3.4 CRC Checksum Calculation

A cyclic redundancy check (CRC) is computed on each data word, in order to verify data integrity. Properties of the CRC check are provided in the **Table 8**.

CRC Property	Value	CRC Algorithm
Polynomial length	1 byte	<pre>CRC_INITIAL_VALUE = 0xFF CRC_POLYNOMIAL = 0x31 def calc_crc(data: bytes) -> int: crc = CRC_INITIAL_VALUE length = len(data) for i in range(length): crc ^= data[i] for _ in range(8): if crc & 0x80: crc = ((crc << 1) ^ CRC_POLYNOMIAL) & 0xFF else: crc = (crc << 1) & 0xFF return crc</pre>
Message length	2 bytes	
Polynomial	0x31	
Initialization	0xFF	
Final XOR	0x00	
Example:		
CRC(0xBEEF) = 0x92		

Table 8. Properties of the CRC.

3.5 Command Overview

All available I2C commands are summarized in the **Table 9**.

Section	Command	Hex Code	Executable During Measurement
3.5.1	<i>start_continuous_measurement</i>	0x00AC	no
3.5.2	<i>read_measurement</i>	0xC0EB	yes, if continuous measurement is running
3.5.3	<i>stop_continuous_measurement</i>	0x50D2	yes
3.5.4	<i>read_serial_number</i>	0x02CE	no
3.5.5	<i>start_selftest</i>	0x060A	no
3.5.6	<i>read_selftest_data</i>	0xC0EB	yes, if self-test is running
3.5.7	<i>perform_soft_reset</i>	0x06 (I2C addr. 0x00)	yes

Table 9. Overview of the I2C commands.

3.5.1 Start Continuous Measurement

After powering on the device, it is in idle state. The *start_continuous_measurement* command initiates the measurement mode, which is required to read out the data. Continuous measurement refers to the autonomous sensor measurements every 0.5 seconds.

Command	Command Hex Code	Read Data	Execution Time (ms)	Description
<i>start_continuous_measurement</i>	0x00AC	-	0	Starts continuous measurement and brings the sensor into the measurement mode.

Table 10. Start continuous measurement command.

3.5.2 Read Measurement

The *read_measurement* command provides information about the formaldehyde concentration, the relative humidity and the temperature. The results are obtained by reading 12 data bytes right after sending the I2C command. While measurement results are updated every 0.5 seconds internally, they can be read at any lower rate, e.g. every 1 second. In case of higher-frequency readout, e.g. every 0.1 seconds, the last available data point will be returned multiple times, until the new data point is available.

In addition, the results contain a status byte, which refers to the readiness of the sensor after power-on. Note that during the first minute after power-on the sensor is not ready (both status bits 0 and 1 being '1'). The formaldehyde concentration output during this first minute is 0. Between 1 minute and 10 minutes after power-on the sensor is ready (the status bit 0 being '0'), but not yet within specifications (the status bit 1 being '1'). After 10 minutes the sensor is ready and within specifications, and both status bits 0 and 1 are '0'. For interpretation of the raw data refer to the **Table 17**.

Command	Command Hex Code	Read Data	Execution Time (ms)	Description
<i>read_measurement</i>	0xC0EB	Byte0: Formaldehyde concentration 8msb Byte1: Formaldehyde concentration 8lsb Byte2: CRC of Byte0 and Byte1 Byte3: Relative humidity 8msb Byte4: Relative humidity 8lsb Byte5: CRC of Byte3 and Byte4 Byte6: Temperature 8msb Byte7: Temperature 8lsb Byte8: CRC of Byte6 and Byte7 Byte9: Sensor status Byte10: Reserved, always returns 0 Byte11: CRC of Byte9 and Byte10	0	Reads out formaldehyde concentration, relative humidity and temperature data. In addition, includes status information.

Table 11. Read measurement data command. Each group of 3 bytes represents an unsigned 16-bit integer (u16), where “msb8” stands for its most significant 8 bits, “lsb8” stands for its least significant 8 bits, and CRC is the checksum of the whole 16-bit message. An exception is Byte9, which represents an unsigned 8-bit integer (u8). For interpretation of the raw data and information about the units refer to the **Table 17**.

3.5.3 Stop Continuous Measurement

The *stop_continuous_measurement* command brings the sensor from the measurement mode back to the idle state.

Command	Command Hex Code	Read Data	Execution Time (ms)	Description
<i>stop_continuous_measurement</i>	0x50D2	-	25	Stops continuous measurement and brings the sensor into the idle mode.

Table 12. Stop continuous measurement command.

3.5.4 Read Serial Number

Each sensor has a unique serial number that is assigned by Sensirion during production. To get the serial number, the sensor has to be in idle state (no running measurement). The 48-bit serial number is (*serial_number_part1* << 32 | *serial_number_part2* << 16 | *serial_number_part3*), where “<<” is the operator for bit shifts to the left.

Command	Command Hex Code	Read Data	Execution Time (ms)	Description
<i>read_serial_number</i>	0x02CE	Byte0: Serial number part1 8msb Byte1: Serial number part1 8lsb Byte2: CRC of Byte0 and Byte1 Byte3: Serial number part2 8msb Byte4: Serial number part2 8lsb Byte5: CRC of Byte3 and Byte4 Byte6: Serial number part3 8msb Byte7: Serial number part3 8lsb Byte8: CRC of Byte6 and Byte7	0	Reads out unique identifying serial number of the sensor.

Table 13. Read serial number command. Each group of 3 bytes represents an unsigned 16-bit integer (u16), where “msb8” stands for its most significant 8 bits, “lsb8” stands for its least significant 8 bits, and CRC is the checksum of the whole 16-bit message.

3.5.5 Start Self-test

The self-test is a special autonomous test, able to detect certain malfunctions, e.g. due to bad soldering during assembly. The test checks the integrity of electric connections between the user interface and the sensor cell. It is recommended to run the self-test once, after the sensor has been soldered to the PCB.

After powering on the device, it is in idle state. The *start_selftest* command initiates a special measurement mode. Refer to **Section 3.5.6** for instructions on how to read out the sensor data after starting the self-test.

Command	Command Hex Code	Read Data	Execution Time (ms)	Description
<i>start_selftest</i>	0x060A	-	0	Starts self-test and thereby brings the sensor into special measurement mode for 5 – 6 minutes.

Table 14. Start self-test command.

3.5.6 Read Self-test Data

After starting the self-test, the *read_selftest_data* command is used to obtain the selftest status and result. The result is obtained by reading 3 data bytes right after sending the I2C command. It is recommended to trigger a readout e.g. every 10 seconds, until the output is different from 65535 (hex: FFFF).

Command	Command Hex Code	Number of read bytes	Execution Time (ms)	Description
<i>read_selftest_data</i>	0xC0EB	Byte0: Self-test result 8msb Byte1: Self-test result 8lsb Byte2: CRC of Byte0 and Byte1	0	Self-test status or result

Table 15. Read self-test data command. Each group of 3 bytes represents an unsigned 16-bit integer (u16), where “msb8” stands for its most significant 8 bits, “lsb8” stands for its least significant 8 bits, and CRC is the checksum of the whole 16-bit message. For interpretation of the raw data refer to the **Table 17**.

3.5.7 Perform Soft Reset

The *perform_soft_reset* command triggers a soft reset of the sensor through the I2C general call reset as implemented according to the *NXP I2C-bus specification and user manual, Ed. 7*. During the execution time, the sensor will not acknowledge its I2C address nor accept commands. The general call I2C address is 0x00

and the command is 1 byte long. Please note that all devices on the same I2C bus designed to respond to a general call I2C reset will undergo a soft reset.

Command	Command Hex Code	Number of read bytes	Execution Time (ms)	Description
<i>perform_soft_reset</i>	0x06	-	25	Resets the sensor.

Table 16. Perform soft reset command.

3.6 Conversion and Interpretation of the Signal Output

Signal	Sym.	Int.	Conversion Formula/ Interpretation	Units
Formaldehyde concentration	C	u16	$C = 0.1 \cdot Output$	ppb
Relative humidity	RH	u16	$RH = 125 \cdot \frac{Output}{65535} - 6$ if RH < 0: RH = 0 if RH > 100: RH = 100	%RH
Temperature	T _C	u16	$T_C = 175 \cdot \frac{Output}{65535} - 45$	°C
	T _F		$T_F = 315 \cdot \frac{Output}{65535} - 49$	°F
Status	-	u8	Interpretation <ul style="list-style-type: none"> status[0]: Sensor not ready (<1 min after power-up) status[1]: Sensor not yet within specifications (<10 min after power-up) when both status bits are 0, sensor is reading within specifications 	-
Self-test result	-	u16	Interpretation <ul style="list-style-type: none"> 65535 (hex: FFFF): Test is still running. Wait longer. 0: Test is finished and passed. Any other number: Test is finished and failed. 	-

Table 17. Signal output interpretation and conversion formulas.

3.6.1 Pseudocode

An example code for starting a measurement, reading and interpreting the measurement results, and finally stopping the measurement is shown in **Figure 5**.

```

I2C_write[0x5D, 0x00AC] # Start a measurement, see Section "Command Overview"
wait_seconds(1.0) # Minimum waiting time is 0.7 s
rx_bytes = I2C_write[0x5D, 0xC0EB] # Read 1st data point, see Section "Command Overview"
hcho_ticks = rx_bytes[0] * 256 + rx_bytes[1]
checksum_hcho = rx_bytes[2] # Checksum of rx_bytes[1:0]
assert calc_crc(hcho_ticks.to_bytes(length=2, byteorder='big')) == checksum_hcho
rh_ticks = rx_bytes[3] * 256 + rx_bytes[4]
checksum_rh = rx_bytes[5] # Checksum of rx_bytes[4:3]
assert calc_crc(rh_ticks.to_bytes(length=2, byteorder='big')) == checksum_rh
t_ticks = rx_bytes[6] * 256 + rx_bytes[7]
checksum_t = rx_bytes[8] # Checksum of rx_bytes[7:6]
assert calc_crc(t_ticks.to_bytes(length=2, byteorder='big')) == checksum_t
status_ticks = rx_bytes[9]
checksum_status = rx_bytes[11] # Checksum of rx_bytes[10:9]
assert calc_crc(status_ticks.to_bytes(length=2, byteorder='big')) == checksum_status

hcho_ppb = hcho_ticks/10
rh_pRH = -6 + 125 * rh_ticks/65535
if (rh_pRH > 100):
    rh_pRH = 100
if (rh_pRH < 0):
    rh_pRH = 0
t_degC = -45 + 175 * t_ticks/65535

wait_seconds(1.0) # Recommended minimum waiting time is 0.7 s
rx_bytes = I2C_write[0x5D, 0xC0EB] # Read 2nd data point, see Section "Command Overview"

... # Repeat interpretation above

wait_seconds(1.0)
rx_bytes = read_measurement() # Read 3rd data point, see Section "Command Overview"

... # Repeat interpretation above

I2C_write[0x5D, 0x50D2] # Stop measurement, see Section "Command Overview"

```

Figure 5. Pseudocode for periodic measurements of SFA40 sensor.

4 Physical Specifications

4.1 Package Description

SFA40 consists of a metal cap on a PCBA board (COB package). The sensor opening is protected by a membrane on the metal cap. The protective membrane must not be removed or tampered with. It is recommended to process the sensors within one year after delivery date.

4.2 Package Outline

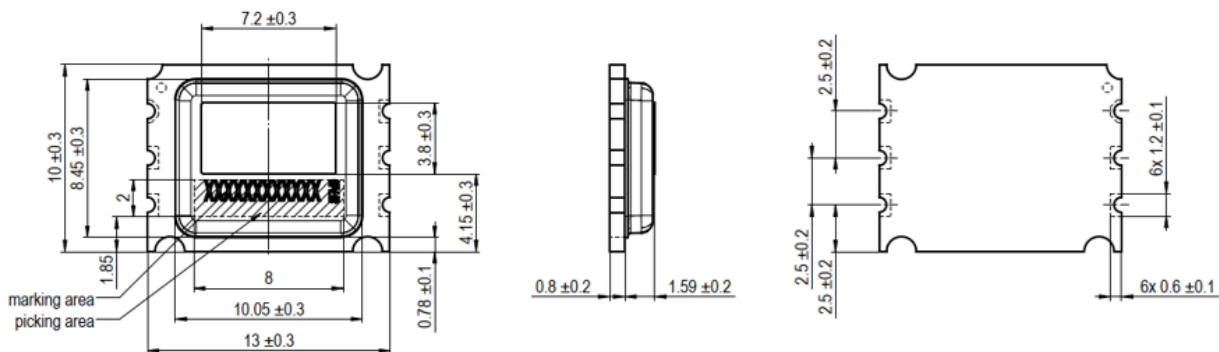

Figure 6. Physical dimensions of the SFA40 sensor (all dimensions in mm): top, side and bottom view.

4.3 Land Pattern

It is recommended to design the sensor's land pattern according to the PCB design and soldering specifications in IPC-7351b-14-11. There must be no conductive material directly underneath the sensor, except at the soldering pads. Electrical connection between the round pads at the back of the PCB must be avoided, as it may lead to short circuits. For reference, the land pattern recommendation is given in Figure 7.

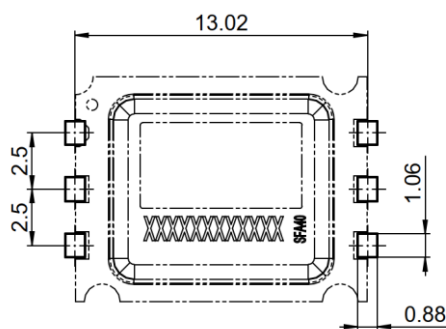

Figure 7. Recommended land pattern (in mm). There must be no conductive material underneath the sensor other than at the soldering pads.

4.4 Soldering and Desoldering Instructions

The sensor is designed for manual soldering and automated soldering with a soldering robot. The sensor **must not** be reflow soldered. Standard (high-temperature) or low-temperature reflow soldering may severely impact the performance of SFA40 and must be avoided.

Shorts between metal cap and castellations, between different castellations and between pads at the backside of the PCB must be avoided. The metal cap protects the electronic components from mechanical and ESD damage and it is connected to ground.

When a soldering iron is used to solder devices to a PCB board the following conditions must be observed:

1. Use a soldering iron with temperature control at the tip (30 – 80 W soldering iron recommended). The soldering iron tip temperature must not exceed 310 °C.
2. Apply the solder to land pattern before pulling the liquid solder to castellations.
3. The soldering period for each castellation must not exceed 5 seconds.

Robot soldering or automated laser soldering may also be used, if the soldering period for each castellation does not exceed 5 seconds.

If desoldering of the SFA40 from the PCB board is required, it is recommended to use desoldering tweezers. Alternatively, removing the solder for each castellation individually using a soldering iron may be used. Heating the full PCB board with the SFA40 on a hot plate must be avoided, as it may irreversibly damage the sensor.

5 Tape and Reel Packaging

SFA40 is available in two different package sizes: 250-piece reel and 1000-piece reel. Reel diameter is the same for both package sizes: 13 inches. Tape and reel packaging specifications are summarized in **Figure 8**.

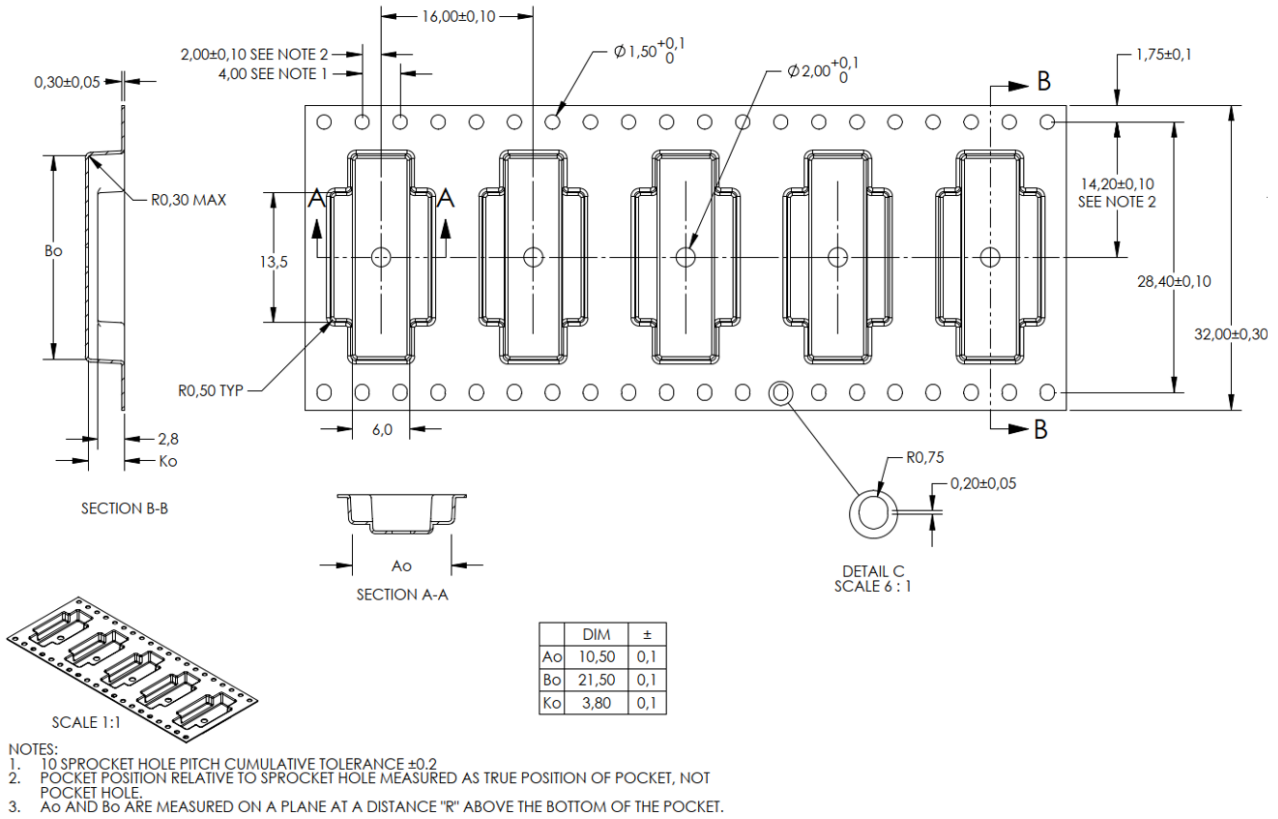

Figure 8. Tape and reel specifications (all dimensions in mm).

5.1 Material Specifications

Parameter	Conditions
REACH, RoHS, Halogen-free	Compliant

Table 18. Material specifications.

6 Ordering Information

Material Description	Material Number	Details
SFA40-D-R1	3.001.250	SFA40-D-R1 250 pcs, Formaldehyde Sensor
SFA40-D-R3	3.001.251	SFA40-D-R3 1000 pcs, Formaldehyde Sensor
SEK-SFA40-Sensor	3.001.217	SEK-SFA40-Sensor Evaluation Kit

Table 19. SFA40 ordering information.

The SEK-SFA40 evaluation kit is designed for effortless testing and includes the following:

- Evaluation kit PCBA with SFA40.
- Cable for easy connection of the PCBA to the Sensirion sensor bridge (material number 3.000.124). Please note that sensor bridge is not included in the SEK-SFA40.
- Jumper wire cable set for easy connection of the PCBA to embedded prototyping platforms, for example Arduino or Raspberry Pi.

Sensirion software, *Control Center*, is designed for testing of Sensirion evaluation kits. It is available for download on Sensirion website, [ControlCenter software | Sensirion](#).

7 Revision History

Date	Version	Pages	Changes
April 2026	1.0	all	Initial release

Important Notices

Warning, Personal Injury

Do not use this product as safety or emergency stop devices or in any other application where failure of the product could result in personal injury (including death). Do not use this product for applications other than its intended and authorized use. Before installing, handling, using or servicing this product, please consult the data sheet and application notes. Failure to comply with these instructions could result in death or serious injury.

If the Buyer purchases or uses SENSIRION products for any unintended or unauthorized application, Buyer shall defend, indemnify and hold harmless SENSIRION and its officers, employees, subsidiaries, affiliates and distributors against all claims, costs, damages and expenses, and reasonable attorney fees arising out of, directly or indirectly, any claim of personal injury or death associated with such unintended or unauthorized use, even if SENSIRION is allegedly negligent with respect to the design or the manufacture of the product.

ESD Precautions

The inherent design of this component causes it to be sensitive to electrostatic discharge (ESD). To prevent ESD-induced damage and/or degradation, take customary and statutory ESD precautions when handling this product. See application note "ESD, Latchup and EMC" for more information.

Warranty

SENSIRION solely warrants to the original purchaser of this product for a period of 12 months (one year) from the date of delivery that this product is of the quality, material and workmanship defined in SENSIRION's published specifications of the product. Within such period, if proven to be defective, SENSIRION shall as sole and exclusive remedy, in SENSIRION's discretion, repair this product or send a replacement product, free of charge to the Buyer, provided that:

- notice in writing describing the defects shall be given to SENSIRION within fourteen (14) days after their appearance;
- such defects shall be found, to SENSIRION's reasonable satisfaction, to have arisen from SENSIRION's faulty material or workmanship;
- the defective product shall be returned to SENSIRION's factory at the Buyer's expense; and
- the warranty period for any repaired or replaced product shall be limited to the unexpired portion of the original period.

The Buyer shall at its own expense arrange for any dismantling and reassembly that is necessary to repair or replace the defective product. This warranty does not apply to any product which has not been installed or used within the specifications recommended by SENSIRION. EXCEPT FOR THE WARRANTIES EXPRESSLY SET FORTH HEREIN, SENSIRION MAKES NO WARRANTIES, EITHER EXPRESS OR IMPLIED, WITH RESPECT TO THE PRODUCT. ANY AND ALL WARRANTIES, INCLUDING WITHOUT LIMITATION, WARRANTIES OF MERCHANTABILITY OR FITNESS FOR A PARTICULAR PURPOSE, ARE EXPRESSLY EXCLUDED AND DECLINED.

SENSIRION is only liable for defects of this product arising under the conditions of operation provided for in the data sheet and proper use of the goods. SENSIRION explicitly disclaims all warranties, express or implied, if the goods are operated or stored not in accordance with the technical specifications.

SENSIRION does not assume any liability arising out of any application or use of any product or circuit and specifically disclaims any and all liability, including without limitation indirect, consequential, and incidental damages, and loss of profit. No obligation or liability shall arise or grow out of SENSIRION's rendering of technical advice, consulting, or implementation instructions or guidelines. All operating parameters, including without limitation recommended parameters, must be validated for each Buyer's applications by Buyer's technical experts. Recommended parameters can and do vary in different applications.

SENSIRION reserves the right, without further notice, (i) to change the product specifications and/or the information in this document and (ii) to improve reliability, functions and design of this product.

Headquarters and Subsidiaries

Sensirion AG

Laubisruetistr. 50
CH-8712 Staefa ZH
Switzerland
phone: +41 44 306 40 00
fax: +41 44 306 40 30
info@sensirion.com
www.sensirion.com

Sensirion Inc., USA

phone: +1 312 690 5858
info-us@sensirion.com
www.sensirion.com

Sensirion Korea Co. Ltd.

phone: +82 31 337 7700~3
info-kr@sensirion.com
www.sensirion.com/kr

Sensirion Japan Co. Ltd.

phone: +81 45 270 4506
info-jp@sensirion.com
www.sensirion.com/jp

Sensirion China Co. Ltd.

phone: +86 755 8252 1501
info-cn@sensirion.com
www.sensirion.com/cn

Sensirion Taiwan Co. Ltd

phone: +886 2 2218-6779
info@sensirion.com
www.sensirion.com

To find your local representative, please visit
www.sensirion.com/distributors