

**Gas metering solutions**  
Thermal-mass technology

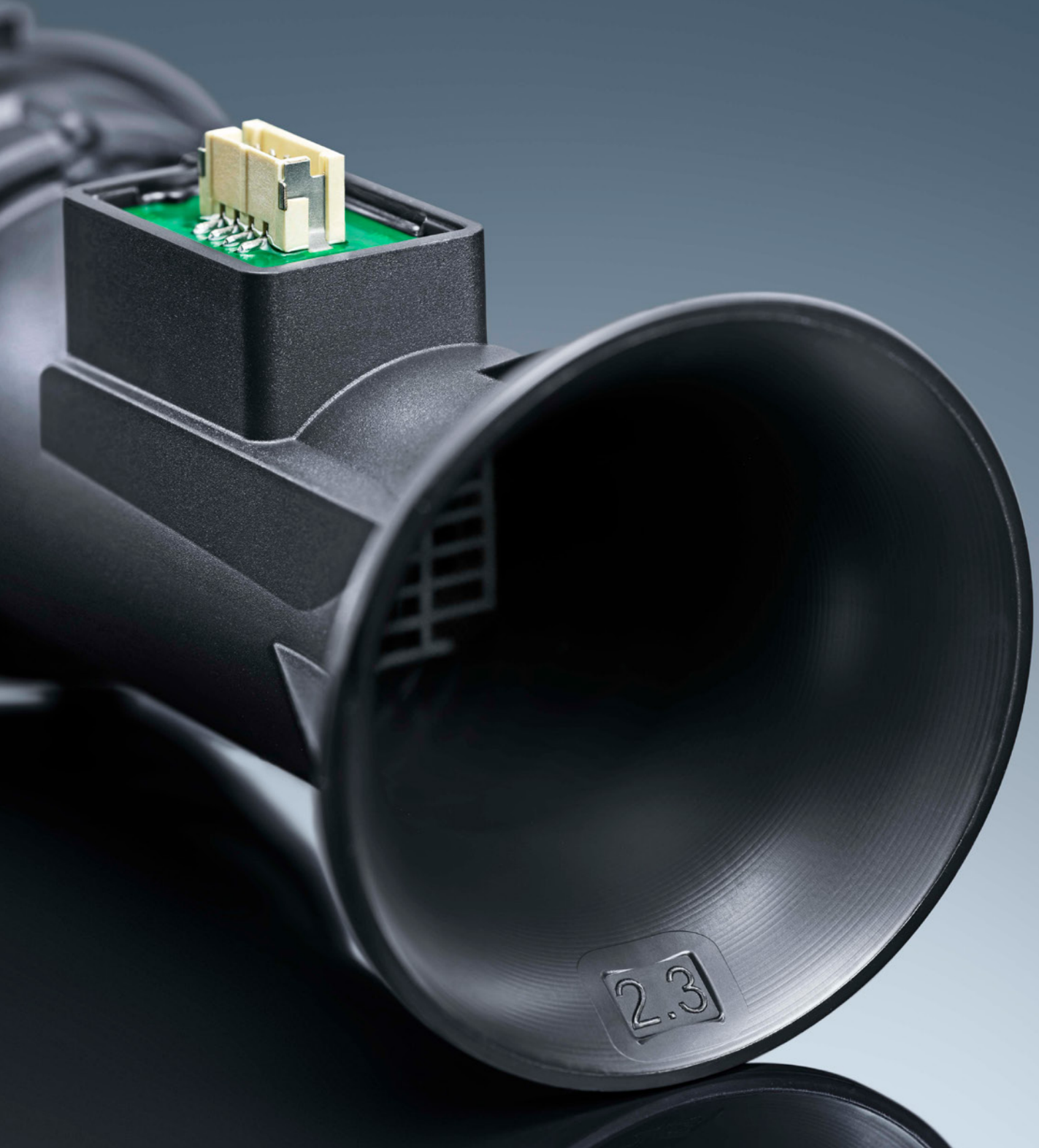

**SENSIRION**

# Thermal-mass modules for smart gas metering



Sensirion gas meter modules are based on the thermal-mass measurement principle, which is currently the best technology to measure flow and is used in high volumes in a wide range of challenging key applications in the automotive, medical and industrial sectors. Sensirion's success can be attributed to the proven CMOSens® Technology, which combines the sensor and analysis electronics on a single semiconductor chip. This technology provides excellent sensor performance and robustness with ultra-low power consumption and attractive costs.

## Thermal-mass measurement principle

At the heart of every Sensirion gas meter module is a MEMS-based calorimetric microsensors, which measures the flow of natural gas using the thermal-mass measurement principle. The sensor element is located on a membrane and consists of a micro-heater and upstream and downstream temperature sensors. It is integrated with the signal conditioning electronics, including memory for calibration data, on a single CMOSens® chip.

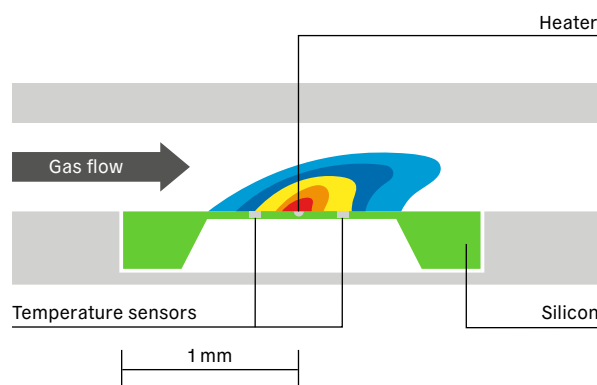

## H2 and biomethane ready

The distribution gas network is evolving with the introduction of renewable gases like biomethane and hydrogen. This infrastructure includes gas meters, which must be able to measure natural gas, hydrogen blends and eventually pure hydrogen. It is highly recommended to future-proof a meter and prepare it for this transition already, as this will prevent the need for meter replacement when hydrogen enters the pipes.

Gas meters incorporating thermal-mass gas meter modules are the ideal candidates for the new renewable gases or gases landscape. Thanks to the unique measurement principle, the same thermal-mass sensor can measure natural gas, LNG, biomethane, H2 blends and pure H2. This is despite the need for hydrogen flow rates to be three times higher compared to natural gas (e.g. G4 meters have  $Q_{max}$  of 6 m<sup>3</sup>/h for natural gas and 20 m<sup>3</sup>/h for hydrogen to compensate for hydrogen's calorific value, which is three times lower). It is a unique feature that cannot be easily implemented with a diaphragm or other static metering technologies, which either have to be tripled in size or require additional complexity and cost for high hydrogen content.



## Evaluation certification

Sensirion's standard gas meter modules have achieved evaluation certification in accordance with the harmonized standard EN 14236, EN 17526 and OIML R 137. The evaluation certificates are issued by NMI and Tifer-nogas, which are leading notified bodies in Europe for type approval examination and certification of measuring instruments. The evaluation certification enables easier and faster MID approval for gas meter manufacturers that use Sensirion's thermal-mass sensor modules as the core metrological unit in their gas meters.

# Thermal-mass technology – key features

## Established technology

Proven by over 11 million meters in the field, billions of hours of reliable metering and independent laboratory tests after 10 years of field installation.

## Natural gas, biomethane and hydrogen

Ready for the future and any gas mixture, including natural gas types H, L and E, LNG, H<sub>2</sub> blends, pure H<sub>2</sub> and biomethane.

## Cut battery costs and increase gas meter life

Thanks to ultra-low power consumption of <105 mAh/year with further improvements for the next generation.

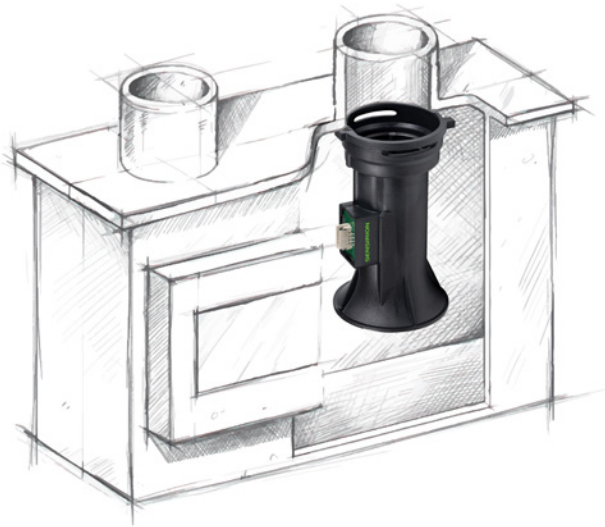

## Compact static meter and lower logistics costs

Thanks to its compact size and no moving parts. The meter size is independent of the H<sub>2</sub> content.

## No need for a volume converter

Sensors output volume flow referred to standard temperature and pressure (standard m<sup>3</sup>/h) or just have the out temperature compensated at ambient pressure.

## Detect leakages

Equip your meter with leak detection functionality, thanks to ultra-low flow sensitivity and the sensor's absolute pressure output.

## Lower certification costs

Reduce your meter certification costs by 30% thanks to sensor evaluation certification according to EN 14236, EN 17526 and OIML R 137.

## A clear H<sub>2</sub> ratio in the gas

The module can determine the H<sub>2</sub> ratio in the gas mixture. This information can be used for grid monitoring purposes, shared with environmentally conscious consumers and used for connected appliances.

## Zero service costs

No more need for meter recalibration thanks to zero offset and zero sensor drift. No moving parts mean no wear and tear.

## Tamper-proof and smart

Enable smart features like tamper detection, self-diagnostics and grid analytics.

## Competitive on costs

Thanks to a streamlined design, high-volume production and a high level of integration on a semiconductor chip.

## Gas calorific value estimation and towards energy metering

This forms the foundation for the implementation of natural gas energy content monitoring in the future. The feature will enable gas utilities to gain a better and more detailed understanding of gas quality, detecting issues with biomethane or H<sub>2</sub> injection points in the distribution network.

# Class 1.5 gas meter modules

Sensirion offers gas meter modules for residential and industrial smart gas metering applications. They fulfill MID accuracy class 1.5, and are available for gas meter sizes G1.6 to G25. They feature a digital I<sup>2</sup>C interface and are fully calibrated for air and natural gas.

Sensirion's gas meter modules have achieved evaluation certification in accordance with the harmonized standard EN 14236, EN 17526 and OIML R 137 for natural gas containing up to 23% H<sub>2</sub> (e.g. limit gas G222 according to EN 437). The latest products can also measure up to 100% H<sub>2</sub>.



## Specification of flow ranges

Parameter	G1.6	G2.5	G4	G6	G10	G16	G25	Unit
Q <sub>min</sub>	0.016	0.025	0.040	0.060	0.100	0.160	0.250	m <sup>3</sup> /h
Q <sub>t</sub>	0.250	0.400	0.600	1.00	1.60	2.50	4.00	m <sup>3</sup> /h
Q <sub>max</sub>	2.50	4.00	6.00	10.0	16.0	25.0	40.0	m <sup>3</sup> /h
Q <sub>start</sub>	< 0.25 Q <sub>min</sub>							
Q <sub>overflow</sub>	2 Q <sub>max</sub>							
Q <sub>reverse</sub>	-0.2 Q <sub>max</sub>							

## Physical specifications

Parameter	Description	Value	Unit
Temperature	Operating temperature	-25 to 55	°C
Humidity	Operating humidity in natural gas	0 to 40	% RH
Accuracy (for T = 15°C)	Flow range: Q <sub>reverse</sub> ≤ Q ≤ -Q <sub>min</sub>	± 10	% m.v.
	Flow range: Q <sub>min</sub> ≤ Q < 0.1Q <sub>max</sub>	± 3.0 (+0.5)	% m.v.
	Flow range: 0.1Q <sub>max</sub> ≤ Q ≤ Q <sub>max</sub>	± 1.5 (+0.5)	% m.v.
Initial pressure drop without meter housing	Pressure drop at Q <sub>max</sub>	< 1.0	mbar in air

## Electrical specifications

Parameter	Value	Unit
Operating voltage	2.7 to 3.6	Vdc
Average current consumption (approx.) <sup>1</sup>	< 12	μA
	< 105	mAh/year
Electrical interface	I <sup>2</sup> C	

<sup>1</sup> Exact power consumption depends on the exact electronic host environment.

# Complete design solution

Sensirion provides a support package to enable fast and easy integration of Sensirion gas meter modules into customer gas meter products.

## Sensirion gas meter modules



### Evaluation certification

Make use of the Sensirion evaluation certification to gain MID approval faster and more easily for gas meter products that use Sensirion gas meter modules as the core metrological unit.



### Complete documentation

Integrate Sensirion gas meter modules into gas meter products quickly and efficiently, thanks to comprehensive documentation.



### Evaluation kit

Perform a basic technology evaluation of Sensirion thermal-mass gas modules using the convenient evaluation kit, including readout software.



### Electronic reference design

Use the Sensirion electronic board, including sample code, as a reference during implementation of the sensor-relevant firmware code for a thermal-mass gas meter.



### Benchtop measurement setup

Perform flow characterization of Sensirion gas meter modules with Sensirion's compact R&D benchtop setup for flow measurement.



### Partner network

Benefit from Sensirion's partner network in the gas meter component industry.



Technology at heart,  
future in mind.