

Datasheet – SGD43S-M3-Sx

A2L Refrigerant Detection System for HVACR applications based on Thermal Conductivity Measurement



Product Summary

The SGD4x sensor family is Sensirion’s series of gas concentration sensors designed for the HVAC industry. The SGD4x utilizes a revolutionized thermal conductivity measurement principle, which results in superior repeatability and long-term stability, especially in harsh conditions and high temperature applications. Coming with additional temperature and humidity sensors for output compensation, the SGD4x is the perfect choice for applications where reliability is key.

The sensor is fully calibrated and compensated for maximum accuracy and ease of integration. Furthermore, the sensor has been designed to be compliant with the relevant norms for refrigerant detection sensors (UL 60335-2-40 and UL 60335-2-89). The outstanding performance of these sensors is based on Sensirion’s patented CMOSens® sensor technology, which combines the sensor element, signal processing and digital calibration on a single, all-solid-state silicon CMOS chip.

The SGD4x sensors are self-monitoring according to UL 60335-2-40 ed. 4.1.

The SGD43S member of the SGD4x family features 24V AC/DC input, a dual relay switch output, an RS-485 serial interface, and a dual color status light. The SGD43S qualifies as either a REFRIGERANT SENSOR or a REFRIGERANT DETECTION SYSTEM depending on its configuration in the appliance’s circuitry, according to UL 60335-2-40 and UL 60335-2-89.

Highlights

- Calibrated gas concentration sensing
- Self-monitored sensing for reliable performance over time
- Dual relay output & digital interface
- Maintenance-free, > 15 year lifetime
- Status indication via LED



WARNING

This datasheet contains important Warnings and Notices about the sensor handling, installation, and operation. To ensure proper and safe operation of the sensor, all the warnings must be followed.

Operating the sensor outside the limits specified in this datasheet may temporarily or permanently inhibit the sensor’s ability to respond to refrigerant, reduce its accuracy and increase its response time. This can result in risk of fire, explosion and damage to property, injuries and death.

Integration of the sensor in the appliance must be carried out by qualified personnel who is capable of identifying risks and avoiding potential hazards when designing or working with these products and systems.

Contents

1	Sensor Performance	3
1.1	Refrigerant Sensing Specifications	3
1.2	Temperature and Humidity Sensing Specifications	4
2	Specifications.....	5
2.1	Electrical Specifications.....	5
2.2	Environmental Conditions	7
2.3	Timing Specifications.....	8
2.4	Absolute Maximum Ratings.....	9
2.5	Pin Assignment	10
2.6	Block Diagram	10
2.7	Materials	11
2.8	Environmental Protection	11
3	Sensor Operation.....	12
3.1	Modbus Interface	12
3.1.1	Bus Specification	12
3.1.2	Register Map	12
3.1.3	Warning Table.....	15
3.2	Relay and Status Light Operation.....	15
3.2.1	Relay Contact Operation.....	16
3.2.2	Status Light Operation.....	17
4	Mechanical Specifications	18
4.1	Sensor Dimensions	18
4.2	Sensor Orientation.....	19
4.3	Sensor Mounting.....	20
4.4	Handling and Installation.....	20
5	Sensor Markings.....	21
5.1	Text and Symbols.....	21
5.2	Data Matrix 2D Code	22
6	Important Notices	23
6.1	Warranty	24
7	Ordering Information.....	25
8	Revision History.....	25



Scan me to provide feedback

1 Sensor Performance

1.1 Refrigerant Sensing Specifications

All values for new sensors at ambient conditions (15...25°C, 30...70% RH, 86...108 kPa) as per UL 60335-2-40 Annex LL.2.1DV and UL 60335-2-89, unless noted otherwise.

	<p>NOTICE: The sensor qualifies as either a REFRIGERANT SENSOR or a REFRIGERANT DETECTION SYSTEM depending on its configuration in the appliance's circuitry as per UL 60335-2-40 and UL 60335-2-89. The sensor needs to be connected to the appropriate system elements to trigger the required system response.</p>
---	--

Parameter	Symbol	Condition	Min.	Typ.	Max.	Units	Comments
Refrigerant type		Clean air is defined as dry composition of 78% N ₂ , 21% O ₂ , 0.9% Ar, 0.04% CO ₂ plus variable content of H ₂ O depending on the relative humidity.	Refrigerant as specified below in clean air				Clean air according to UL 60335-2-40 3.214DV
Concentration measurement range			0		100	%LFL	
Detection threshold limit value	DTLV	R-32	11			%LFL	Product for the dual-refrigerant setting: SGD43S-M3-S5
		R-454B	12			%LFL	
		R-454A	14			%LFL	Product for the triple-refrigerant setting: SGD43S-M3-S7
		R-454C	14			%LFL	
		R-455A	10			%LFL	
Accuracy at ambient conditions		at DTLV and in clean air			± 2.5	%LFL	According to UL 60335-2-40 Annex LL.4.3DV
Accuracy after stress, at ambient conditions		at DTLV and in clean air			± 5.0	%LFL	For sensors after stress exposure, according to UL 60335-2-40 Annex LL
Accuracy at extreme humidity		at DTLV and in clean air, 0...100% RH*, max. dew point 40°C			± 5.0	%LFL	According to UL 60335-2-40 Annex LL.8DV. * Range evaluated by UL: 5%...95% RH
Accuracy at extreme temperature		at DTLV and in clean air, -40...85°C, max. dew point 40°C			± 5.0	%LFL	According to UL 60335-2-40 Annex LL.9DV

Accuracy at extreme pressure		at DTLV and in clean air, 80...110 kPa,			± 5.0	%LFL	According to UL 60335-2-40 Annex LL.10DV
Response time		Crossing of DTLV after step exposure from clean air to 25% LFL		15	30	s	According to UL 60335-2-40 Annex LL.3.2DV

Table 1: Refrigerant sensing specifications.

1.2 Temperature and Humidity Sensing Specifications

	NOTICE: Temperature and humidity values are measured inside the sensor measurement cell. The measurement cell is equipped with a heating element, therefore temperature and humidity as provided by the sensor may differ significantly from actual ambient conditions.
---	--

Parameter	Symbol	Condition	Min.	Typ.	Max.	Units	Comments
Temperature measurement range			-45		100	°C	
Humidity measurement range			0		100	%RH	

Table 2: Temperature and humidity sensing specifications.

2 Specifications

2.1 Electrical Specifications



All values for new sensors at ambient conditions (15...25°C, 30...70% RH, 86...108 kPa) as per UL 60335-2-40 Annex LL.2.1DV and UL 60335-2-89, unless noted otherwise.

Parameter	Symbol	Condition	Min.	Typ.	Max.	Units	Comments
AC supply voltage	V_{RMS}		18	24	30	V AC	RMS voltage
AC supply voltage frequency	f_{AC}		45	60	66	Hz	
AC supply voltage interruption tolerance			67			ms	3 AC line cycles
AC supply current	I_{RMS}			120	200	mA	
AC active power consumption				0.9		W	
AC inrush current					5	A	Hot plugging must be avoided
DC supply voltage	V_{DD}		21.6	24	26.4	V DC	24V ±10%
DC supply current average				39	70	mA	
Tolerated DC inrush current					5	A	Inrush current should be limited to the stated value by the power supply. Hot plugging must be avoided
Tolerated DC voltage slew rate					25	V/ms	Voltage slew rate should be limited to the stated value by the power supply. Hot plugging must be avoided
DC power consumption					1.5	W	
Relay contact switching current (pins 4, 6, 7, 8)					1000	mA	
Relay contact AC switching voltage (pins 6, 7)					30	V AC	
Relay contact DC switching voltage (pins 6, 7)					26.4	V DC	min switching load 10 µA 10 mV DC

Relay contact AC switching power (pins 4, 6, 7, 8)					37	VA	Resistive load
Relay contact DC switching power (pins 4, 6, 7, 8)					27	W	Resistive load
RS-485 single line input voltage			-5		12	V	Referenced to GND
RS-485 single line output voltage			0		3.3	V	Referenced to GND
RS-485 differential output voltage		At 54 Ohm, 50 pF external load	1.5	2		V	
RS-485 positive-going differential-input threshold voltage					-45	mV	
RS-485 negative-going differential-input threshold voltage			-200			mV	
RS-485 output current			-60		60	mA	
RS-485 differential load resistor			54			Ohm	

Table 3: Electrical specifications.

2.2 Environmental Conditions

	WARNING: The sensor measurement cell is equipped with a heating element to reduce the risk of condensation. Especially during dynamic and transient conditions, the risk of condensation cannot be fully eliminated. The equipment manufacturer is responsible for assessing the risk of condensation in the application. Condensation buildup in or on the sensor can inhibit or delay the sensor response to refrigerant.
	WARNING: The sensor is equipped with an electromechanical relay. The relay is not rated for condensing environments. The equipment manufacturer is responsible for assessing the risk of condensation in the application.

Parameter	Symbol	Condition	Min.	Typ.	Max.	Units	Comments
Calibrated temperature		Temperature range in which the accuracy holds, see Table 1 .	-40		85	°C	
Operating temperature	T _{OP}	Temperature range in which the sensor may be operated	-40		85	°C	
Operating ambient humidity	RH _{OP}	Condensing, maximum dew point 40°C.	0*		100*	% RH	Condensation is tested for a limited mission profile. Relay rated for 5 – 85%RH and non-condensing environments. * Range evaluated by UL: 5%...95% RH
Operating dew point	DP _{OP}				40	°C	
Operating pressure	p _{OP}		800		1100	mbar	
Operating altitude			0		2000 (6560)	m (ft)	Altitude above sea level
Recommended storage temperature		Non-freezing	5	20	60	°C	Recommended conditions for long-term storage
Recommended storage humidity		Non-condensing	0	50	85	% RH	Recommended conditions for long-term storage.



Table 4: Environmental conditions.

2.3 Timing Specifications

Parameter	Symbol	Condition	Min.	Typ.	Max.	Units	Comments
Power-up time	t_{PU}				2	s	Time from power-up to first measurement available through the digital interface
Warm-up time				5		s	Time until sensor accuracy is within specification after power-up
Update period			800	1000	1200	ms	New measurement result available

Table 5: Timing specifications.

2.4 Absolute Maximum Ratings

	NOTICE: The following values are stress levels. Prolonged exposure to these conditions may result in degradation of performance or lifetime.
	WARNING: Hot-plugging the sensor may exceed the listed voltage slew rate or inrush current and permanently damage the sensor.

Parameter	Symbol	Condition	Min.	Typ.	Max.	Units	Comments
Storage temperature		Short-term storage during e.g. transport	-45		70	°C	
Input voltage V_{IN} (pin 1)		With respect to GND	-50		50	V	
Input voltage RS-485 (pins 3, 5)		With respect to GND	-50		50	V	
Input voltage relay contacts (pins 6,7)		With respect to GND	-50		50	V	
Inrush current V_{IN} (pin 1)					30	A	Hot plugging must be avoided
Voltage slew rate V_{IN} (pin 1)					100	V/ms	Hot plugging must be avoided
Relay contact AC switching voltage (pins 6, 7)					40	V AC	
Relay contact AC switching power (pins 4, 6, 7, 8)					37.5	V A	
Relay contact DC switching voltage (pins 6, 7)					30	V DC	
Relay contact DC switching power (pins 4, 6, 7, 8)					30	W	
RS-485 input current (pins 3, 5)			-24		24	mA	
ESD protection contact discharge					6	kV	According to IEC 61000-4-2
ESD protection air discharge					8	kV	According to IEC 61000-4-2

Table 6: Absolute maximum ratings.

2.5 Pin Assignment

Pin no.	Name	Description
1	V _{IN}	Input voltage (AC or DC)
2	GND	Connect to ground
3	D+	RS-485 D+/A
4	NO2	Relay contact normally open 2
5	D-	RS-485 D-/B
6	COM1	Relay dry contact common 1
7	NO1	Relay dry contact normally open 1
8	NC2	Relay contact normally closed 2

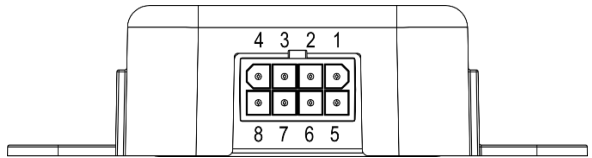

Table 7: SGD43S-M3-Sx pin assignment (front view).

2.6 Block Diagram

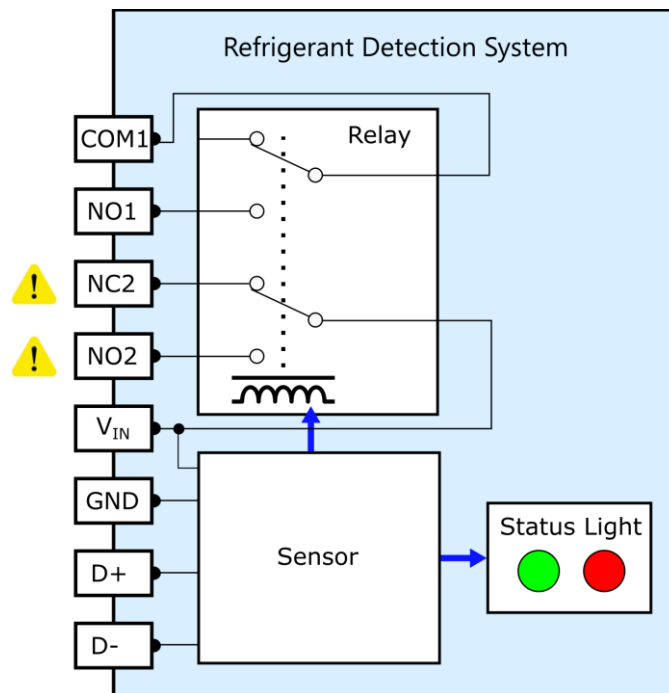



Figure 1: Block diagram of SGD43S-M3-Sx. Operation modes are graphically shown in Section 3.2.



WARNING: Depending on the sensor's state, NC2 or NO2 is connected to V_{IN} via the relay. Connecting without a suitable load may lead to excess current on the relay and permanently damage the relay. Excess current on the relay through COM1 and NO1 must also be avoided.

2.7 Materials

Parameter	
Housing material	UV stabilized, impact modified flame-retardant Polybutylene Terephthalate/Polycarbonate (PBT), unreinforced
Housing sealing material and status light see-through material	Vulcanized Ethylene Propylene Thermoplastic (TPE)
Flammability	UL 94 V-0
Compliance	RoHS

Table 8: Materials.

2.8 Environmental Protection

Parameter	Description	Comments
IP rating	IP54	When plugged into IP54 rated connector.

Table 9: Environmental Protection.

3 Sensor Operation

3.1 Modbus Interface

The following specifications refer to SGD43S-M3-Sx Firmware Interface version 1.0.

3.1.1 Bus Specification

Parameter	Description
Bus type	Modbus RTU, RS-485
Byte order	Big endian
CRC order	Little endian
Frame	1 start bit, 8 data bits, 2 stop bits, no parity
Inter-frame-silence	>3.5 characters
Baud rate	38'400 bps. Supports 1200 – 115'200 bps
Modbus address	0x01 (default), supports 1-247
Supported function codes	0x03 (Read holding registers) 0x06 (Write single holding register)
Supported exception codes	Illegal function Illegal data address Illegal data value Server device failure

Table 10: Modbus specifications.

3.1.2 Register Map



	NOTICE: Data spread over multiple registers must be read in a single transaction, starting at the first register address.
---	--

Access	Name	Register Address	Number of registers	Data Type	Description
R	Register specification version	0x0100	1	[uint8, uint8]	Version of the protocol specification. High byte is major, low byte minor number.
W	Device reset	0x0101	1	bool	The ASIC and microcontroller are reset if '1' is written to this register. Warning bits can be cleared by applying reset. Range: 0 – 1
Data query					
R	Operating mode	0x0110	1	enum	The operating mode of the device. There are no measurements available during startup. 0: Startup 1: Measuring

R	Leak signal	0x0111	1	bool	<p>A flag that turns on when the concentration exceeds the alarm threshold. The leak signal is sustained for 5 minutes after the concentration is again below the leak signal threshold.</p> <p>0: No leak detected 1: Active leak detection or sustain period after leak detection</p>
R	Warnings	0x0112	1	uint16	<p>Table 12 below lists the warnings.</p>
R	Gas concentration	0x0113	1	int16	<p>The last measured gas concentration in %LFL multiplied by 10 (example: 251 for 25.1 %LFL).</p> <p>On the SGD43S-M3-S5, the gas concentration is given in %LFL R-454B. On the SGD43S-M3-S7, the gas concentration is given in %LFL R-454C.</p> <p>Resolution: 0.1 %LFL Range: 0 – 100 %LFL (clamped) Default: 0 (the default value is displayed during startup until the first measurement arrives)</p>
R	Sensor temperature	0x0114	1	int16	<p>The last measured sensor temperature in °C multiplied by 10 (example: 210 for 21°C).</p> <p>Resolution: 0.1°C Range: -45 – 130°C Default: 0 (the default value is displayed during startup until the first measurement arrives).</p>
R	Sensor humidity	0x0115	1	uint16	<p>The last measured sensor humidity in %RH multiplied by 10 (example: 305 for 30.5 %RH).</p> <p>Resolution: 0.1 %RH Range: 0 – 100 %RH Default: 0 (the default value is displayed during the startup until the first measurement arrives).</p>
R	Approximate sensor dewpoint	0x0116	1	int16	<p>The dew point computed from the last measured sensor humidity and temperature multiplied by 10 (example: 210 for 21°C).</p> <p>Uncertainty: ±2°C Resolution: 0.1°C Range: -86 – 130°C</p>
Settings					
R/W	Device address	0x0120	1	uint8	<p>Slave address of the Modbus interface. A device reset (see register 0x0101) or power cycle is required to apply a change of this value. After writing a new device address, the warning register</p>

					(0x0112) should be checked for no warning before the reset. Range: 1 – 247 (as per Modbus specification) Default: 1
R	Leak signal threshold	0x0124	1	uint16	The gas concentration level that triggers the leak signal (see register 0x0111). Resolution: 0.1 %LFL (example: 251 for 25.1 %LFL)
W	Status light	0x0126	1	uint16	The status lights are disabled if a '0' is written to this register. This will turn off both the green and red status light. The status lights are enabled if a '1' is written to this register. Default: 1
Device Info					
R	Device marking	0x0140	10	string[20]	Reads the device marking which uniquely identifies a sensor. Format: YYWWNNNNNN, where YY: year, WW: week, NNNNNN: running number
R	Firmware version	0x014A	1	uint8[2]	Firmware Version Format, e.g. 0.14: High byte: Major version, e.g. 0 (0x00) Low byte: Minor version, e.g. 14 (0x0E)
R	Gas type	0x014C	1	enum	The gas type the sensor is configured for. 6: R-32 / R-454B (default on SGD43S-M3-S5) 8: R-454A / R-454C / R-455A (default on SGD43S-M3-S7)
R	Lifetime counter	0x014E	1	uint16	The device's elapsed lifetime. Resolution: 1 day (example: 365 for 1 year) Range: 0 – 65535 days (~179 years)
R	Maintenance state	0x014F	1	uint16	Gets the end-of-lifetime state based on the sensor's self-monitoring by checking the warning flags in the device status. 0: No concern 1: EOL warning 2: EOL reached
R	System up time	0x0151	2	uint32	Device running time since last reset/power cycle. Resolution: 1 second (example: 3600 for 1 hour) Range: 0 – 4.2 billion seconds (~136 years)

Table 11: Modbus registers.

	NOTICE: Registers 0x0110 to 0x0116 are meant to be read in a “read multiple” transaction which includes the warning flags (0x0112). The warning flag indicates the validity of the other values at the same moment in time.
	NOTICE: It is advised to check the SELF-CHECK FAILED warning flag after writing changes to register 0x0120 and before a reset to prevent the sensor from applying an unexpected configuration.
	NOTICE: Note that the gas concentration output is only given in %LFL R-454B on the SGD43S-M3-S5, and only given in %LFL R-454C on the SGD43S-M3-S7.

3.1.3 Warning Table

Bit index	Meaning	Comment	Recovery Action
0	Internal error	Internal error that results in untrustworthy measurement data.	Wait, if persisting, try a reset
1	Value out of limit	Gas concentration, temperature, or dew point out of range.	Environmental condition
2	Self-check failed	Checks supply voltage, internal sensor errors, FW errors.	Check supply voltage, if ok, might be cleared by reset
3	Permanent error	Any error which is not recoverable, e.g. self-monitoring end-of-life.	Replace sensor
4	Over lifetime limit	The lifetime limit is reached.	Replace sensor
5	Low supply voltage	Checks only for low supply voltage to complement error bit 6. Will be raised when supply voltage < 18 V for over 2.5 seconds.	Check supply voltage
6	Internal self-check failed	Same as error bit 2, excluding the low supply voltage check, as this is considered an external error.	Reset/power-cycle sensor
7...15	<i>Reserved</i>	<i>Reserved for future use.</i>	

Table 12: Modbus warning register bit assignment

	WARNING: Bits 0, 2, 3, 4, 5, 6 of the warning register are mapped to the FAULT state. These warnings will trigger the relay response and the status light response as described in Section 3.2.1 and 3.2.2 respectively. Bit 1 of the warning register does not map to FAULT.
---	--

3.2 Relay and Status Light Operation

The following block diagrams visually represent the operation mode of the relay and status light.

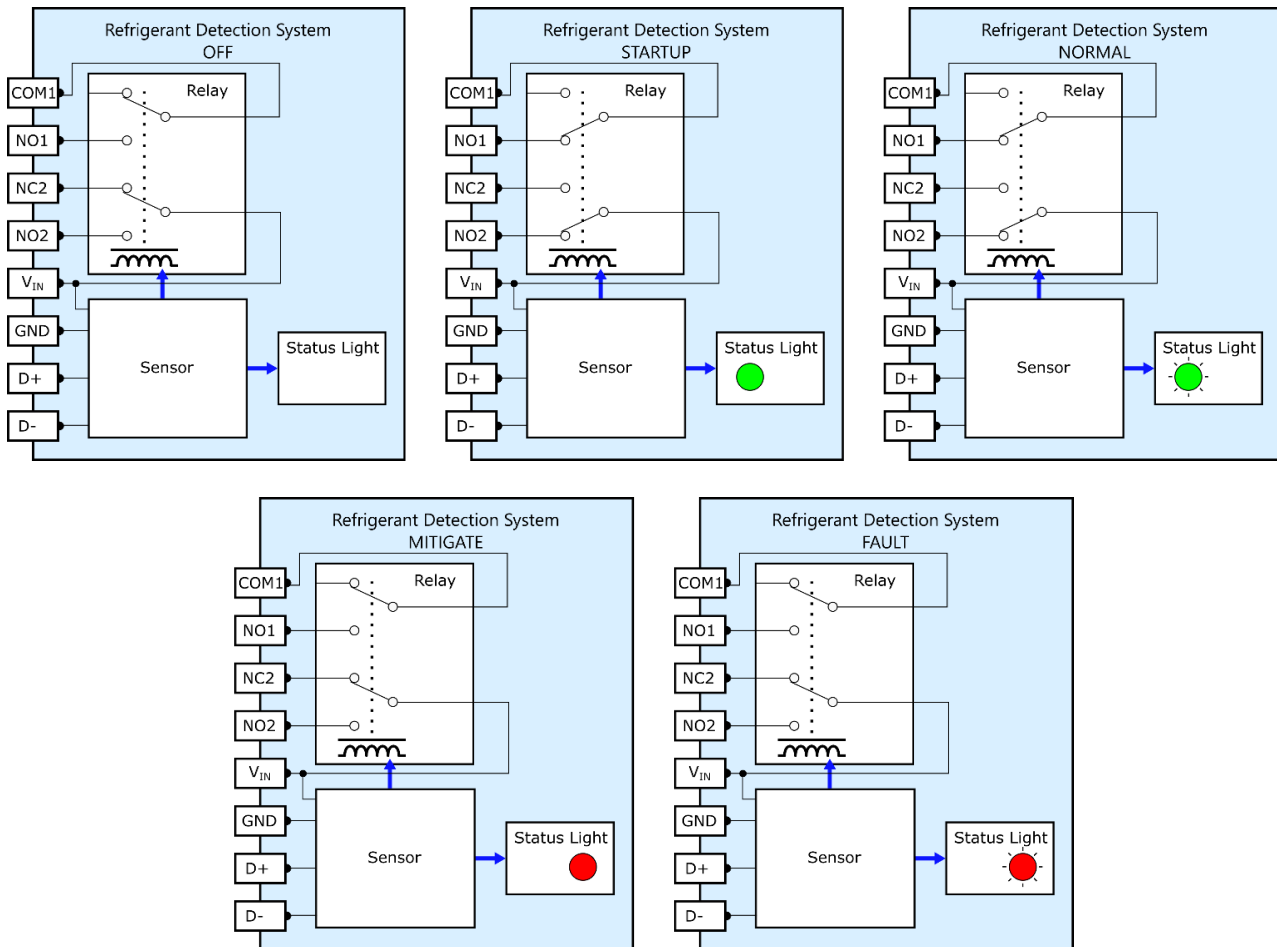

Figure 2: Block diagram of relay and status light operation. The five states of SGD43S-M3-Sx are: OFF (top left), startup mode (top center), normal operation mode (top right), alarm mode (bottom left), and fault mode (bottom right). Relay operation is further detailed in **Section 3.2.1**. Status light operation is further detailed in **Section 3.2.2**.

3.2.1 Relay Contact Operation



The sensor’s relay contacts remain **not energized** (normally-open open, normally-closed closed) if any of the following conditions are met:

- Sensor is unpowered
- Sensor is in FAULT state
- Sensor is out of calibration as determined by the self-monitoring algorithm
- Sensor has reached its end-of-life as determined by the self-monitoring algorithm
- Sensor is in MITIGATE state

The sensor’s relay contacts remain **energized** (normally-open closed, normally-closed open) if all of the following conditions are met:

- Sensor is powered
- Sensor is in STARTUP state or sensor is in NORMAL state (the sensor is operating normally)
- The measured refrigerant concentration is below the detection limit threshold value (DTLV)

When a refrigerant leak has been detected, the sensor goes into the MITIGATE state. After the refrigerant concentration is again below the detection threshold limit value (DTLV), the sensor remains in the MITIGATE state for the leak sustain period. The relay remains not energized during the leak sustain period. The leak sustain period is set to 5 min (300 s) on both the SGD43S-M3-S5 and the SGD43S-M3-S7.



	<p>WARNING: In normal operation (no mitigate no fault) the relay is closed while the sensor is powered. In the event of a mitigate or fault situation, the relay must open. In case the relay is stuck in closed state, no mitigate or fault state can be indicated by the sensor. No self-test is possible to verify normal relay operation (relay not stuck) when the sensor is powered. The sensor must be powered off periodically by the appliance control and correct electromechanical operation of the relay (open relay in power-off state) must be confirmed.</p>
	<p>WARNING: If the relay output is shortened (e.g. by misuse by the end-user), the sensor cannot indicate a mitigate or fault state (open relay contact). The sensor must be powered off periodically by the appliance control and expected behavior of the relay output (open relay in power-off state) must be confirmed.</p>
	<p>NOTICE: Following leak detection, if the sensor loses power during the leak sustain period, the sensor will not persist with the not-energized relay state when powered up again.</p>

3.2.2 Status Light Operation

Status Light	Sensor mode
Green continuous	STARTUP. The sensor is starting up.
Green blinking	NORMAL. The sensor is in normal operation mode.
Red continuous	MITIGATE. The sensor has detected a leak.
Red blinking	FAULT. The sensor has a fault.

Table 13: List of status light operation.

The status light remains in red continuous mode during the leak sustain period, defined in **Section 3.2.1**.

	<p>NOTICE: The status lights can be turned off using the digital interface. Turning off the status light will disable visual monitoring of the sensor.</p>
	<p>NOTICE: Following leak detection, if the sensor loses power during the leak sustain period, the sensor will not persist with the status light red continuous state when powered up again.</p>

4 Mechanical Specifications

4.1 Sensor Dimensions

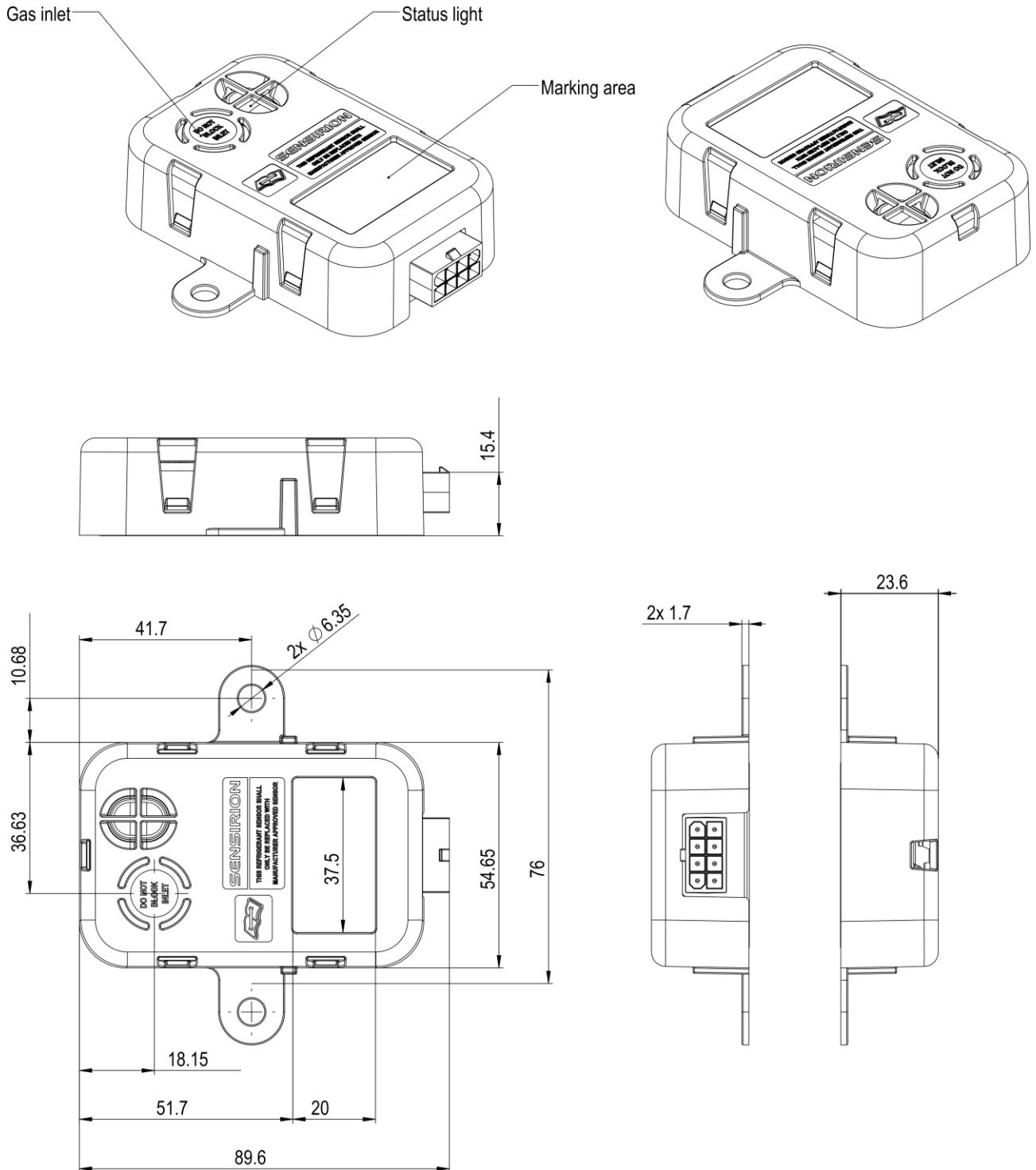

Figure 3: Physical dimensions of the SG43S-M3-Sx in mm. Tolerances according to DIN ISO 2768-c.

4.2 Sensor Orientation

The sensor shall always be mounted in the vertical position (see **Figure 4**), with the gas inlet facing sideways. Within this configuration, the connector should not be mounted with the connector facing upwards (see **Figure 5**).

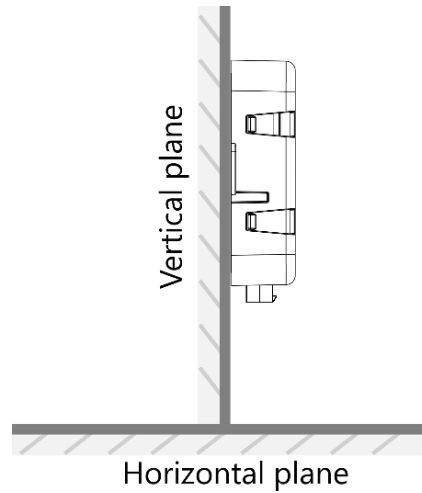

Figure 4: Recommended mounting position for SGD43S-M3-Sx sensor.

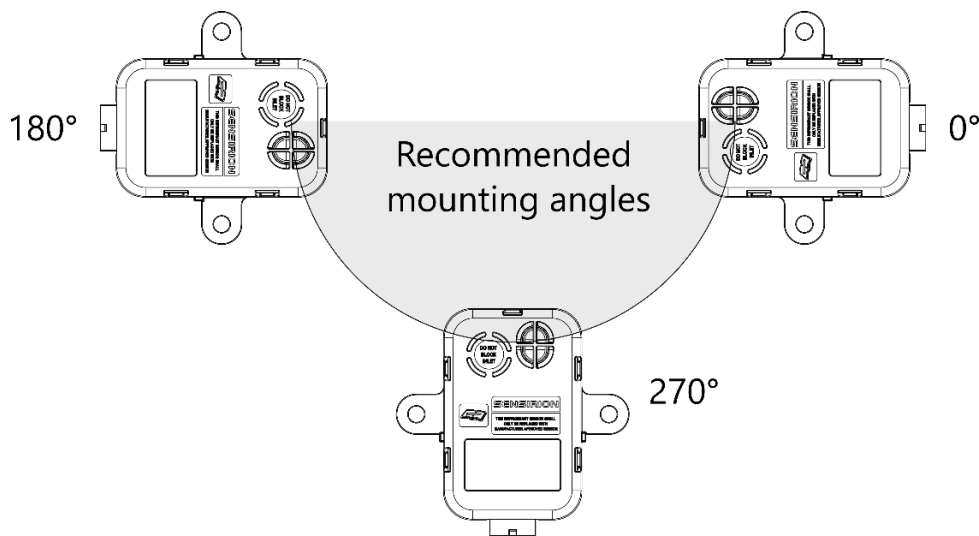



Figure 5: Recommended mounting angles in the vertical configuration (see **Figure 4**) for SGD43S-M3-Sx. Any angle denoted by the gray semicircle is acceptable. Any configuration with the connector facing upwards should be avoided due to the risk of water ingress.

	<p>WARNING: The sensor must not be installed with the gas inlet facing upwards in situations where water might accumulate on or in the sensor. Accumulated water in the sensor may delay or inhibit the sensor’s response to refrigerant.</p>
	<p>NOTICE: The sensor should not be installed with the connector facing upwards, especially in situations where water or condensate may be dripping on the sensor from above.</p>



4.3 Sensor Mounting

The sensor shall be mounted on a flat surface using the mounting holes provided, using a suitable method depending on the application. If mounted by screws, a #10-32 screw must be used, and the torque applied must not exceed 0.7 Nm.

	<p>WARNING: The sensor's gas inlet must not be blocked. A blocked or restricted gas inlet may delay or inhibit the sensor's response to refrigerant.</p>
---	---

4.4 Handling and Installation

The sensor shall be handled, installed, and replaced by qualified personnel only. The appliance manufacturer shall indicate in the appliance manual that sensor repair must be avoided.

	<p>WARNING: The sensor contains no repairable or serviceable parts and cannot be repaired. A damaged, non-working or malfunctioning sensor must be replaced by a qualified and trained person.</p>
	<p>WARNING: Cleaning products might damage the sensor or temporarily block its gas inlet, inhibiting or delaying the response to the refrigerant. It is the responsibility of the appliance manufacturer to determine the appropriate way to allow for cleaning of the appliance without damaging or blocking the sensor, and to instruct the maintenance personnel and end user on how this operation should be performed.</p>

5 Sensor Markings

5.1 Text and Symbols

The SGD43S-M3-Sx is marked with the following text and symbols.

Field	Location	Marking Method	Marking	Comment
Replacement warning	Mounting bracket	Static text in injection mold	THIS REFRIGERANT SENSOR SHALL ONLY BE REPLACED WITH MANUFACTURER APPROVED SENSOR	According to UL 60335-2-40 Annex LL.16DV
“Service indicator, read technical manual” symbol	Mounting bracket	Static symbol in injection mold	Symbol ISO 7000-1659 (2004-01)	According to UL 60335-2-40 Annex LL.16DV
Inlet warning	Mounting bracket	Static text in injection mold	DO NOT BLOCK INLET	
Sensirion logo	Mounting bracket	Static text in injection mold	SENSIRION	
Supplier Part Number (Sensirion PN)	Sensor body	Laser marking	SGD43S-M3-S5	According to UL 60335-2-40 Annex LL.16DV. On product: SGD43S-M3-S5
			SGD43S-M3-S7	According to UL 60335-2-40 Annex LL.16DV. On product: SGD43S-M3-S7
Serial number (SN)	Sensor body	Laser marking	YYWWNNNNNN	YY: year WW: week number NNNNNN: weekly running number
Gas type	Sensor body	Laser marking	R32 / R454B	On product: SGD43S-M3-S5
			R454A / R454C / R455A	On product: SGD43S-M3-S7
UL file number	Sensor body	Laser marking	E537108	Sensirion’s UL FTAM2 file number
UL mark	Sensor body	Laser marking	UL mark for recognized products	
Data Matrix 2D Code	Sensor body	Laser marking	See Section 5.2	

Table 14: Sensor Markings.

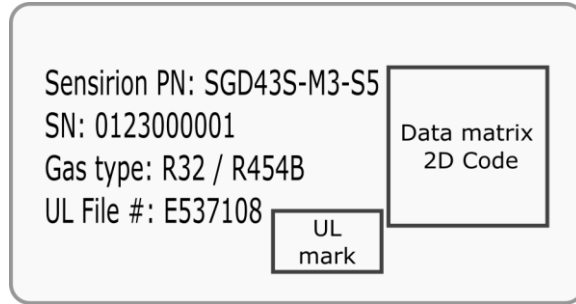

Figure 6: Laser marking example of SGD43S-M3-Sx.

5.2 Data Matrix 2D Code

The 2D data matrix code marked on the sensor is generated according to ISO/IEC 15434 format 6:

Item #	Content	
Item 1	D>	Header
	^{R_S}	Non-printing ASCII control character (30)
	06	Data matrix format code
Item 2	^{G_S}	Non-printing ASCII control character (29)
	1P	Field identifier for Sensirion part number
	SGD43S-M3-Sx	Sensirion part number SGD43S-M3-S5 or SGD43S-M3-S7
Item 3	^{G_S}	Non-printing ASCII control character (29)
	S	Field identifier for serial number
	YYWWNNNNNN	Serial number
Item 4	^{R_S}	Non-printing ASCII control character (30)
	^{E_{OT}}	Non-printing ASCII control character (4)

Table 15: Structure of the 2D data matrix code marked on the sensor.

Example of 2D data matrix code (separators in **red**, prefixes in **green**):

[D]>^{R_S}**06**^{G_S}**1P**SGD43S-M3-S5^{G_S}**S**0123456789^{R_S}**E_{OT}**

6 Important Notices

PASS ON THIS INFORMATION TO ALL ENTITIES AND PERSONNEL INVOLVED IN THE DESIGN, DEVELOPMENT, MANUFACTURING, SELLING AND SERVICING OF GOODS USING THIS PRODUCT.

Warning, personal injury

This product is an electronic A2L refrigerant detection system and a refrigerant sensor for air conditioning units and heat pumps. The product is intended for appliance manufacturer integration by qualified personnel that can identify risks and avoid potential hazards when working and designing with these products and systems. This product can only be used in conjunction with certification agencies listed appliances and systems.

This product is either a Refrigerant Detection System or a Refrigerant Sensor by the relevant norms (UL 60335-2-40 and UL 60335-2-89) depending on its configuration. It is the responsibility of the appliance manufacturer to provide mitigation action when appropriate. These instances include, but are not limited to, whenever the refrigerant detection system triggers a mitigation action, whenever the detected refrigerant concentration exceeds the limit set by the appliance manufacturer, whenever a sensor error is present, whenever environmental conditions exceed limits specified in this datasheet, whenever sensor readings cannot be considered relevant (e.g., during sensor startup, lack of or insufficient sensor response due to clogging of gas inlet or other reasons), and in any other situation that can result in personal injury (including death) or property damage.

This product does NOT represent a fail-safe device, even when used in combination with certification agencies listed appliances and components. It is the responsibility of the appliance manufacturer to implement the correct mitigation actions in case of any sensor failure and/or malfunctioning. Failure to do so could result in personal injury (including death). The appliance manufacturer is responsible for the safety of the systems it builds, and that failure of the product does not result in death, injury or property damage. It is also responsible for the correct integration, maintenance, inspection, and servicing of the product and to ensure that the product operates within the limits specified by the present datasheet.

The appliance manufacturer must comply at all times with all requirements, information and Warnings given in the product datasheet, this Important Notice, and all other information provided by SENSIRION. The appliance manufacturer shall include in its manuals and affix to the products the necessary labels and warnings. In case of uncertainty, the appliance manufacturer shall contact SENSIRION for clarification. If not expressly stated otherwise in a supply agreement between SENSIRION and the appliance manufacturer, SENSIRION declines all responsibilities and liabilities to the maximum extent permitted by applicable law.

Do not use this product for applications other than its intended and authorized use. Before installing, handling or using this product, it is mandatory to consult the datasheet and application notes, and all other information provided by SENSIRION. Failure to comply with these instructions could result in death or serious injury.

If the Buyer purchases or uses SENSIRION products for any unintended or unauthorized application, Buyer shall defend, indemnify and hold harmless SENSIRION and its officers, employees, subsidiaries, affiliates and distributors against all claims, costs, damages and expenses, and reasonable attorney fees arising out of, directly or indirectly, any claim of personal injury or death associated with such unintended or unauthorized use, even if SENSIRION is allegedly negligent with respect to the design or the manufacture of the product.

6.1 Warranty

SENSIRION solely warrants to the original purchaser of this product for a period of 12 months (one year) from the date of delivery that this product shall be of the quality, material and workmanship defined in SENSIRION's published specifications of the product. Within such period, if proven to be defective, SENSIRION shall, as sole and exclusive remedy, in SENSIRION's discretion, repair this product, or ship a conforming product, free of charge to the Buyer, provided that:

- notice in writing describing the defects shall be given to SENSIRION within fourteen (14) days after their appearance;
- such defects shall be found, to SENSIRION's reasonable satisfaction, to have arisen from SENSIRION's faulty material or workmanship;
- the defective product shall be returned to SENSIRION's factory at the Buyer's expense; and
- the warranty period for any repaired or replaced product shall be limited to the unexpired portion of the original period.

The Buyer shall at its own expense arrange for any dismantling and reassembly that is necessary to repair or replace the defective product. This warranty does not apply to any product which has not been installed or used within the specifications recommended by SENSIRION.

EXCEPT FOR THE WARRANTIES EXPRESSLY SET FORTH HEREIN, SENSIRION MAKES NO WARRANTIES, EITHER EXPRESS OR IMPLIED, WITH RESPECT TO THE PRODUCT. ANY AND ALL WARRANTIES, INCLUDING WITHOUT LIMITATION, WARRANTIES OF MERCHANTABILITY OR FITNESS FOR A PARTICULAR PURPOSE, ARE EXPRESSLY EXCLUDED AND DECLINED. SENSIRION is only liable for defects of this product arising under the conditions of operation provided for in the data sheet and proper use of the goods. SENSIRION explicitly disclaims all warranties, express or implied, if the goods are operated or stored not in accordance with the technical specifications, manuals, and other information provided by SENSIRION. SENSIRION does not assume any liability arising out of any application or use of any product or circuit and specifically disclaims any and all liability, including without limitation indirect, consequential, and incidental damages, and loss of profit. No obligation or liability shall arise or grow out of Sensirion's rendering of technical advice, consulting, or implementation instructions or guidelines. All operating parameters, including without limitation recommended parameters, must be validated for each customer's applications by the customer's technical experts. Recommended parameters can and do vary in different applications. SENSIRION reserves the right, without further notice, (i) to change the product specifications and/or the information in this document and (ii) to improve reliability, functions and design of this product.

7 Ordering Information

Product Name	Order Number	Comment
SGD43S-M3-S5	3.001.158	Refrigerant R-32/R-454B
SGD43S-M3-S7	3.001.186	Refrigerant R-454A/R-454C/R-455A

Table 16: Ordering Information.

8 Revision History

Date	Version	Section(s)	Changes
04.10.2024	1.0	All	Initial version.
09.01.2025	1.1	1.1, 2.1, 5 2.1 2.4 2.6 3.1.1 3.2.1	Added UL 60335-2-89 Updated relay ratings Updated maximum relay ratings Warning added to NO2 and NC2. Warning added to figure Modbus table typo Added information on the leak sustain period
25.02.2025	1.2	3.1.2 3.2.1	0x0111, leak signal is sustained for 5 min on all variants The leak sustain period is set to 5 min on all variants

Table 17: Revision History.