

# Handling Instructions

## For SCD4x Photoacoustic CO<sub>2</sub> Sensors

To take advantage of the outstanding performance of the SCD4x, the following precautions must be taken into account during storage, assembly and packaging. It is important to review these instructions already during the design-in phase / before production release of the respective device.

Furthermore, make sure to read the SCD4x Datasheet thoroughly before consulting this document.

### Key Instructions

- Protection against ESD is mandatory
- Do not remove, damage, imprint or obstruct the white protective membrane on top of the metal sensor cap
- Do not apply excessive shear forces to the metal sensor cap.
- Sensors must be handled according to Moisture Sensitivity Level 1
- Prevent sensor exposure to volatile organic compounds (e.g. solvents/cleaning agents), acids, bases or corrosives
- Soldering instructions and parameter limits must be respected
- Do not vapor phase solder
- Do not apply board wash
- Do not apply spray coating to unprotected sensor

### Contents

1	General.....	2
1.1	ESD.....	2
1.2	Storage.....	2
1.3	Mechanical Handling.....	3
1.4	Exposure to Chemicals.....	3
2	Assembly.....	4
2.1	Pick and Place Process.....	4
2.2	Sensor Reflow Soldering (SMT).....	5
2.3	Conformal Coating.....	5
3	Extreme Conditions.....	7
4	Disclaimer.....	7
5	Revision History.....	7

# 1 General

## 1.1 ESD

The sensor must be protected from ESD (Electrostatic Discharge) at all times and may only be handled in ESD protected areas (EPA) under protected and controlled conditions. This includes grounding all personnel with wrist-straps, grounding all non-insulating and conductive objects and excluding insulating materials from the EPA. All operations should be conducted on a grounded conductive floor. To further protect the sensor, it should be packaged using ESD protective materials when handled outside an EPA.

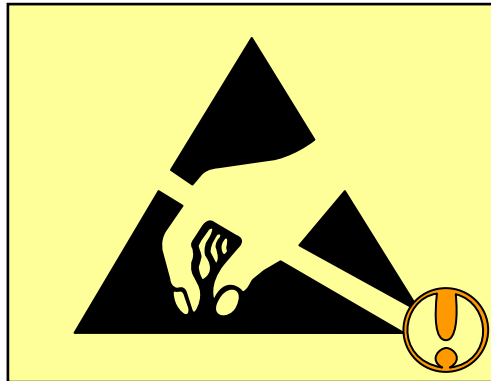

**Instruction 1:** Protection against ESD is mandatory

## 1.2 Storage

SCD4x sensors are classified as Moisture Sensitivity Level 1 components (IPC/JEDEC J-STD-020). Nevertheless, we recommend storing SCD4x sensors within their original sealed ESD bag prior to assembly within a temperature range of 10°C – 50°C. It is recommended to process sensors within one year of their date of delivery.

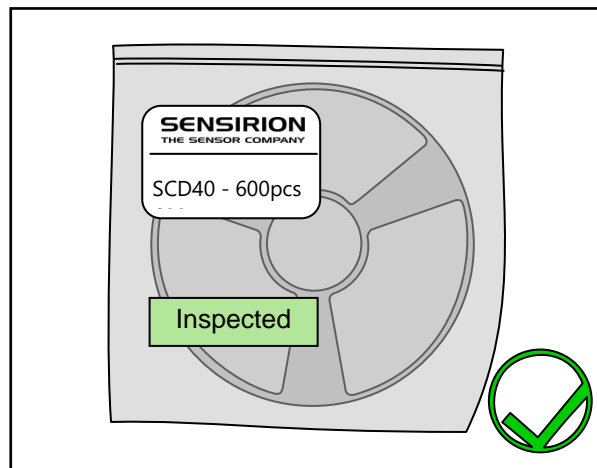

**Instruction 2:** Store sensors in original, unopened ESD bag. Place additional stickers only on the outside of the ESD bag.

Once sensors have been removed from the original ESD bag, it is recommended to store them or the devices comprising them within antistatic shielded ESD bags at normal pressure (i.e. bag should not be evacuated). The ESD bags listed in **Table 1** can be recommended for this purpose (no polluting effect on humidity sensor):

Manufacturer	Product	Compatibility
Stroebe	Topshield Bags	Compatible

**Table 1:** ESD Bag compatibility

To avoid contamination of the humidity sensor intrinsic to SCD4x, sensors or the devices that contain them must not be packaged within outgassing plastic materials. As a general guideline: if a material emits a strong odour, it should not be used.

Paper or cardboard-based packaging, or deep drawn plastic trays (PE, PET, PP), may be considered as alternatives to metal-in antistatic shielded ESD bags. Do not use antistatic polyethylene bags, (light blue, pink or rose colour), bubble foils and foams.

Furthermore, the use of adhesives or adhesive tapes for resealing sensor bags after opening should be avoided. Minimize stickers present inside the packaging (e.g., on the housing of the device) and make sure that their sticky side fully adheres to the host surface.

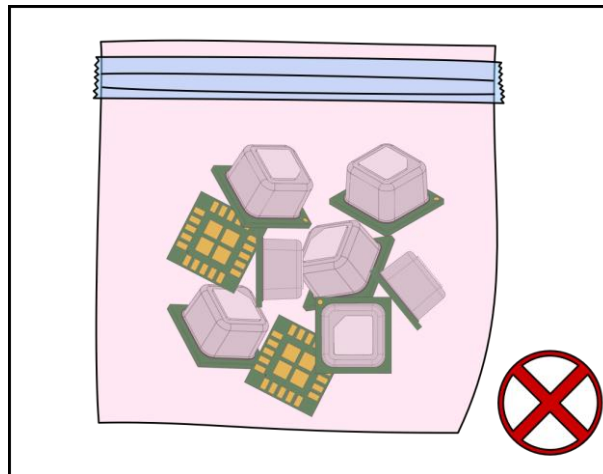

**Instruction 3:** Do not use polyethylene antistatic bags (light blue, pink or rose colour). Do not use adhesive tapes inside packaging.

As an additional resource, Sensirion’s humidity sensor handling instructions provide a list of encapsulants and adhesives known not to contaminate the integrated humidity sensor.

### 1.3 Mechanical Handling

As SCD4x is an optical sensor system, it must not be exposed to extreme mechanical forces. Most importantly, excessive shear forces must not be applied onto the metal sensor cap.

The white protective membrane on top of the metal sensor cap must not be damaged or removed at any point in time. Furthermore, the sensor must not be exposed to strong air blasts from an air-pistol. Partial detachment, removal or minor cuts to the white protective membrane will irreversibly damage the sensor. It is recommended to wear clean gloves or finger cots while handling the sensor and to avoid touching the white protective membrane.

### 1.4 Exposure to Chemicals

In general, the sensor must not get in close contact with volatile chemicals, such as solvents or other organic compounds. Most importantly, long exposure to high concentrations must be avoided. Therefore, it is important to comply with the following:

- Ketenes, acetone, ethanol, isopropyl alcohol, toluene, etc.<sup>1</sup> are known to compromise the accuracy of the intrinsic humidity sensor – in most cases, irreversibly – and should be avoided. Such chemicals

<sup>1</sup> Such chemicals are an integral part of epoxies, glues, adhesives, etc. and outgas during baking and curing. Furthermore, they are frequently added as plasticisers into plastics for packaging materials, which usually out-gas for some time afterwards.

are an integral part of epoxies, glues, adhesives, etc. and outgas during baking and curing. Furthermore, they are frequently added as plasticisers into plastics for packaging materials, which usually out-gas for some time afterwards. Note that the intrinsic RH/T sensor is necessary for precise CO<sub>2</sub> readings over the entire relative humidity and temperature range – even if the RH and T outputs of SCD4x are not used on the application level.

- The sensor must not get in direct contact with strong cleaning agents (e.g., PCB board wash after soldering) or solvents. Some solvents might cause the white protective membrane to detach from the sensor’s metal cap, resulting in an irreversible defect of the sensor.
- Acids and bases, including HCl, H<sub>2</sub>SO<sub>4</sub>, HNO<sub>3</sub> or NH<sub>3</sub>, may damage the sensor irreversibly and must be avoided.
- High concentrations of ozone or H<sub>2</sub>O<sub>2</sub> must also be avoided.

Please note that the above examples are not an exhaustive list of harmful substances. If in doubt, it is highly recommended to thoroughly test for any potential impact of the respective substances on the sensor. In any case, ensure good ventilation (fresh air supply) of manufacturing environments to help avoid high concentrations of volatile chemicals.

## 2 Assembly

### 2.1 Pick and Place Process

The SCD4x footprint, landing pads and the tape & reel dimensions are detailed in the SCD4x datasheet. Note that pins are numbered according to IPC 7351A standard, with pin no. 1 having a chamfered edge. Subsequent pins are counted upwards in the counterclockwise direction when looking at the sensor from the top (facing the white protective membrane). Furthermore, a chamfer in the white protective membrane and a round copper mark on the sensor-PCB indicate the corner closest to pin no. 1.

To avoid damaging the sensor, the SCD4x should be picked from the centre of the white protection membrane with a nozzle that has a plastic contact area (see schematic below). The touchdown force of the nozzle should be adapted such that the nozzle leaves no permanent mark or imprint on the membrane (typically < 5 N). Finally, the outer diameter of the nozzle should be smaller than 4.4 mm.

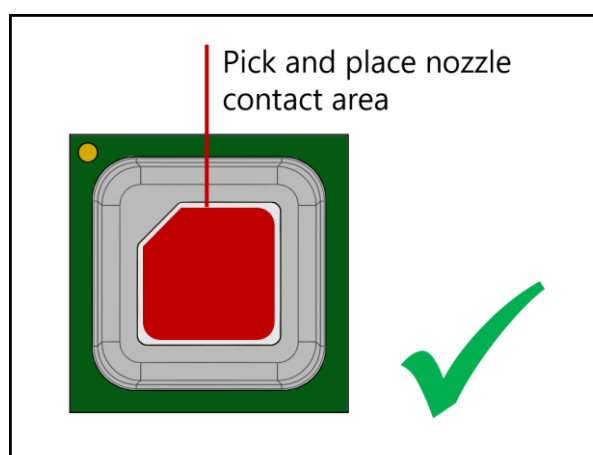

**Instruction 4:** Pick and place the sensor from within the nozzle contact area, leaving no marks or imprints.

## 2.2 Sensor Reflow Soldering (SMT)

Detailed reflow soldering instructions and specifications for the soldering profile can be found in Section 4.5 of the SCD4x datasheet (separate document). Note that SCD4s is not compatible with vapour phase reflow soldering.

Most importantly, the specified maximum peak temperature must not be exceeded at any time in any part of the sensor and must not be applied for any longer than the given time limit. Furthermore, the ramp-down rate must not be faster than the given limit rate for temperatures above the liquidus temperature  $T_L$ . The keep free area around the sensor's thermal relief hole between pads no. 10 and 11 must be respected. Note that exact solder mask, land-pattern geometries and stencil thicknesses must be adapted to the customer soldering process.

SCD4x must not be reflow soldered more than once. In case the device PCB passes through multiple reflow solder cycles (as is the case e.g. for PCBs that are mounted with components on both sides), the SCD4x must be assembled as part of the last solder cycle. Subsequent manual soldering of other PCB components (e.g. through-hole soldering) must not expose SCD4x to temperatures higher than 200 °C.

Do not apply extra flux when reflow soldering the sensor. Furthermore, do not apply board wash after the sensor is assembled onto the PCB.

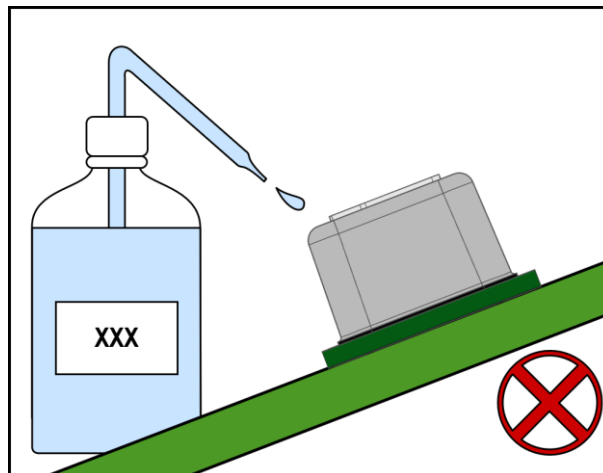

**Instruction 5:** Do not apply board wash after soldering SCD4x.

The sensor shall be mounted into the device after all other materials used in the assembly process have completely cured or dried out. Avoid exposure of the sensor to strong cleaning agents (e.g. detergents, alcohols, brominated or fluorinated solvents) in case rework is conducted on other parts of the host device. In any case, ensure good ventilation (fresh air supply) in curing ovens and assembly lines.

## 2.3 Conformal Coating

Active components of the SCD4x are shielded from environmental influences by the metal cap and the protection membrane. Therefore, conformal coating of the SCD4x is not necessary for most applications.

If a conformal coating is applied to the host-PCB, the white protection membrane of the sensor must not come into contact with any kind of coating to remain permeable to air molecules. A thin layer of conformal coating is enough to fully obstruct the opening into the measurement cavity, thus irreversibly damaging the sensor.

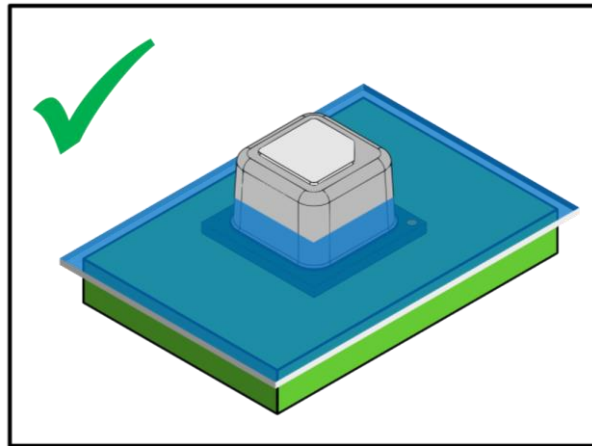

**Instruction 6:** If conformal coating is applied, the protective membrane must remain free of any coating.

The SCD4x is not compatible with spray coating and dip coating. Manual coating with a brush, dispensing and jetting can be used to apply conformal coating on the PCB while ensuring that no coating is applied to the membrane.

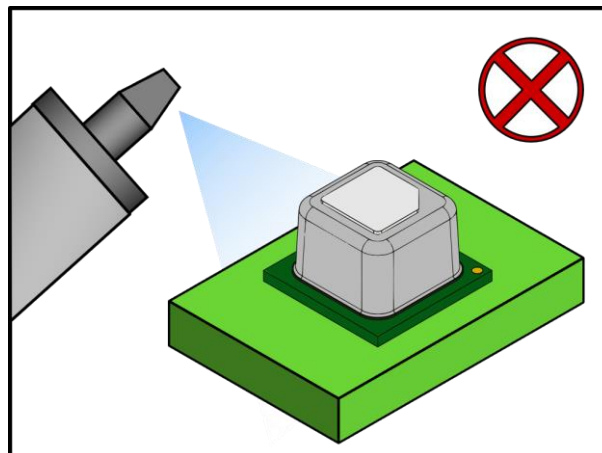

**Instruction 7:** Do not apply spray coating to unprotected sensor.

Conformal coatings must not contaminate the built-in humidity sensor. **Table 2** lists conformal coatings which have been tested regarding pollution of the humidity sensor and are known to be suitable if applied and fully cured under good ventilation (fresh air supply) and according to their respective datasheet.

Manufacturer	Product	Compatibility
Peters	Elpeguard SL 1301 ECO-FLZ	Compatible
Dow Corning	1-2577 Low Voc Conformal Coating	Compatible
Electrolube	AFA (Aromatic Free Acrylic Conformal Coating)	Compatible

**Table 2:** Compatible conformal coatings

### 3 Extreme Conditions

Some applications require exposure to harsh environments. Beware that sensor performance or reliability cannot be guaranteed for conditions outside of the limits specified in the SCD4x datasheet. It is recommended to thoroughly test for any potential impacts extreme conditions may have on the sensor and verify that it can fulfill the requirements of the application.

The absolute maximum ratings for humidity and/or temperature as specified in the SCD4x datasheet must not be exceeded. As a precautionary measure, the self-heating of the sensor when operating it continuously in periodic measurement mode (5 second sampling interval) may help reduce the risk of condensation inside the optical cavity in off-label high-humidity conditions.

See Section 1.4 of this document for instructions regarding exposure to chemicals.

### 4 Disclaimer

Not respecting the recommendations and guidelines detailed in this document and the SCD4x datasheet can result in compromised sensor performance, functionality or sensor failure. Note that the beforementioned restrictions, recommendations, materials, etc. do not comprise all possible cases. It is highly recommended to thoroughly test SCD4x in combination with the intended assembly / handling process(es) to verify their suitability. Please consult the SCD4x Testing Guidelines (separate document) for further details.

The material recommendations provided are in relation to their impact on SCD4x sensors and assume ideal processing for averting VOCs in the process – the materials were not examined with respect to other characteristics such as dependability, efficacy, usefulness, or mechanical properties. The material recommendations have been compiled to the best of our knowledge at the time of writing. Manufacturers may alter the compounds without warning, which can lead to decreased sensor performance due to outgassing.

This document must not be considered exhaustive and is subject to change without prior notice.

### 5 Revision History

Date	Version	Page(s)	Changes
January 2021	1.0	All	Initial release
February 2025	2.0	All	New format, adapted information on moisture sensitivity level according to Infoletter 243401, updated pictograms, clarifications and editorial changes

## Important Notices

### Warning, Personal Injury

Do not use this product as safety or emergency stop devices or in any other application where failure of the product could result in personal injury (including death). Do not use this product for applications other than its intended and authorized use. Before installing, handling, using or servicing this product, please consult the data sheet and application notes. Failure to comply with these instructions could result in death or serious injury.

If the Buyer purchases or uses SENSIRION products for any unintended or unauthorized application, Buyer shall defend, indemnify and hold harmless SENSIRION and its officers, employees, subsidiaries, affiliates and distributors against all claims, costs, damages and expenses, and reasonable attorney fees arising out of, directly or indirectly, any claim of personal injury or death associated with such unintended or unauthorized use, even if SENSIRION is allegedly negligent with respect to the design or the manufacture of the product.

### ESD Precautions

The inherent design of this component causes it to be sensitive to electrostatic discharge (ESD). To prevent ESD-induced damage and/or degradation, take customary and statutory ESD precautions when handling this product. See application note "ESD, Latchup and EMC" for more information.

### Warranty

SENSIRION solely warrants to the original purchaser of this product for a period of 12 months (one year) from the date of delivery that this product is of the quality, material and workmanship defined in SENSIRION's published specifications of the product. Within such period, if proven to be defective, SENSIRION shall as sole and exclusive remedy, in SENSIRION's discretion, repair this product or send a replacement product, free of charge to the Buyer, provided that:

- notice in writing describing the defects shall be given to SENSIRION within fourteen (14) days after their appearance;
- such defects shall be found, to SENSIRION's reasonable satisfaction, to have arisen from SENSIRION's faulty material or workmanship;
- the defective product shall be returned to SENSIRION's factory at the Buyer's expense; and
- the warranty period for any repaired or replaced product shall be limited to the unexpired portion of the original period.

The Buyer shall at its own expense arrange for any dismantling and reassembly that is necessary to repair or replace the defective product. This warranty does not apply to any product which has not been installed or used within the specifications recommended by SENSIRION. EXCEPT FOR THE WARRANTIES EXPRESSLY SET FORTH HEREIN, SENSIRION MAKES NO WARRANTIES, EITHER EXPRESS OR IMPLIED, WITH RESPECT TO THE PRODUCT. ANY AND ALL WARRANTIES, INCLUDING WITHOUT LIMITATION, WARRANTIES OF MERCHANTABILITY OR FITNESS FOR A PARTICULAR PURPOSE, ARE EXPRESSLY EXCLUDED AND DECLINED.

SENSIRION is only liable for defects of this product arising under the conditions of operation provided for in the data sheet and proper use of the goods. SENSIRION explicitly disclaims all warranties, express or implied, if the goods are operated or stored not in accordance with the technical specifications.

SENSIRION does not assume any liability arising out of any application or use of any product or circuit and specifically disclaims any and all liability, including without limitation indirect, consequential, and incidental damages, and loss of profit. No obligation or liability shall arise or grow out of SENSIRION's rendering of technical advice, consulting, or implementation instructions or guidelines. All operating parameters, including without limitation recommended parameters, must be validated for each Buyer's applications by Buyer's technical experts. Recommended parameters can and do vary in different applications.

SENSIRION reserves the right, without further notice, (i) to change the product specifications and/or the information in this document and (ii) to improve reliability, functions and design of this product.

## Headquarters and Subsidiaries

### Sensirion AG

Laubisruetistr. 50  
CH-8712 Staefa ZH  
Switzerland  
phone: +41 44 306 40 00  
fax: +41 44 306 40 30  
[info@sensirion.com](mailto:info@sensirion.com)  
[www.sensirion.com](http://www.sensirion.com)

### Sensirion Inc., USA

phone: +1 312 690 5858  
[info-us@sensirion.com](mailto:info-us@sensirion.com)  
[www.sensirion.com](http://www.sensirion.com)

### Sensirion Korea Co. Ltd.

phone: +82 31 337 7700~3  
[info-kr@sensirion.com](mailto:info-kr@sensirion.com)  
[www.sensirion.com/kr](http://www.sensirion.com/kr)

### Sensirion Japan Co. Ltd.

phone: +81 45 270 4506  
[info-jp@sensirion.com](mailto:info-jp@sensirion.com)  
[www.sensirion.com/jp](http://www.sensirion.com/jp)

### Sensirion China Co. Ltd.

phone: +86 755 8252 1501  
[info-cn@sensirion.com](mailto:info-cn@sensirion.com)  
[www.sensirion.com/cn](http://www.sensirion.com/cn)

### Sensirion Taiwan Co. Ltd

phone: +886 2 2218-6779  
[info@sensirion.com](mailto:info@sensirion.com)  
[www.sensirion.com](http://www.sensirion.com)

To find your local representative, please visit  
[www.sensirion.com/distributors](http://www.sensirion.com/distributors)